

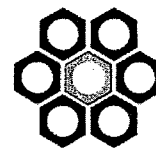

# Bennett Controls

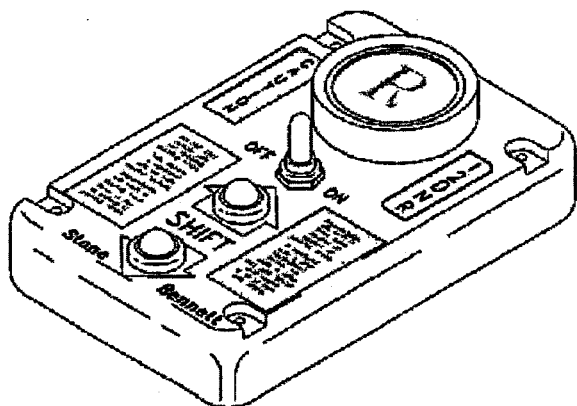

## B-89 Series Shift control Kits



- ⌚ *Auto-Neutral Shifting*
- ⌚ *Neutral-to-Range Inhibitors*
- ⌚ *PTO Overspeed & Lockout*
- ⌚ *RPM Shift Shock Protection*
- ⌚ *Tough Environmental Protection*

With  
LED Displays  
Molded Sealed Connectors  
Sealed Push Buttons  
Surge Protected Throughout

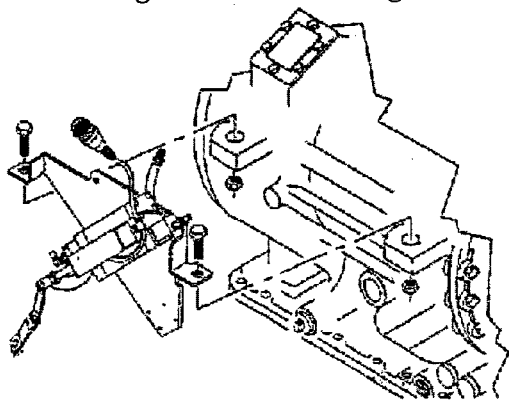

## INSTRUCTION MANUAL

- ⌚ INSTALLATION AND SERVICE GUIDE
- ⌚ TROUBLESHOOTING GUIDE
- ⌚ PARTS GUIDE

For  
Refuse Trucks  
and  
Work Vehicles

Equipped with GM Allison AT, MT or HT  
Series Automatic Transmissions

Exclusively by:

 **Froude Hofmann Inc.**

45225 Polaris Court      Tel: 800-527-0883  
Plymouth, MI. 48170      Fax 734-416-9113  
[www.froudehofmann.com](http://www.froudehofmann.com)

ISO-9001 Registered

# TABLE OF CONTENTS

**Section 1 Installation and Service Guide**

Page

Typical Layout of System .....	1
Installation Bulletin - 14A653Hxx-02 .....	3
Installation Bulletin - BCX-02-12V .....	7
Installation Bulletin - LP3-01 .....	8
Installation Bulletin - LP4-AN-01 .....	13
Installation Bulletin - S-HS653-01 .....	17
Envelope Data - 74xxx.xx .....	20
Envelope S-HS6xx-01 .....	21
Envelope S-HS7xx.01 .....	22
Envelope S-AS6xx-01 .....	23
Envelope S-AS7xx.01 .....	24
Standard Warranty .....	25

**Section 2 Trouble Shooting Guide**

Transmission Detent Logic .....	26
Shifter Operating Logic .....	27
B-89 Functional Schematic .....	28
Operating Instructions .....	29
Preventative Maintenance Guide .....	30
Functional Testing	
Mechanical Testing .....	31
Electrical Testing .....	32
74044.01 Schematic .....	36
74044.01N Schematic .....	37
74046.01 Master Harness Schematic .....	38
74096.01 Extension Harness Schematic .....	39
74587.01 Single Station Panel Harness Schematic .....	40
74587.01D Dual Station Panel Harness Schematic .....	41

**Section 3 Parts Manual**

**Complete System**

Single System Component Identification .....	42
Single Auto-Neutral System Component Identification .....	42
Dual System Component Identification .....	43
Dual Auto-Neutral System Component Identification .....	43
Component Selection Chart .....	44

**Accessory Box**

BCX-02-12V RPM Shift Shock NOM Standard without PTO Protection .....	45
BCX-03-12V RPM Shift Shock NOM Standard with PTO Protection .....	45
BCD-02-12V RPM Shift Shock NOM Standard with PTO, Engage & Pack in Neutral .....	45
BCD-03-12V RPM Shift Shock NOM Standard with PTO, Engage & Pack in Neutral with Reverse Relay .....	45
BCC-02-12V RPM Shift Shock NOM Standard with PTO, Engage-Neutral, Pack in Gear .....	45
BCC-03-12V RPM Shift Shock NOM Standard with PTO, Engage-Neutral, Pack in Gear with Reverse Relay .....	45
BCE-02-12V RPM Shift Shock NOM Standard with PTO, Engage & Pack in Gear .....	45
BCE-02-12V RPM Shift Shock NOM Standard with PTO, Engage & Pack in Gear with Reverse Relay .....	45

### Range Selector - Street/Left Side

Page

LP3-01	Control Panel .....	46
--------	---------------------	----

### Range Selector - Curb/Right Side

LP3-01	Control Panel .....	46
LP4-AN-01	Auto-Neutral .....	47

### Transmission Station - Hydraulic

S-HS654-01	Hydraulic for MT-654 7 Range - Side Mount .....	48
S-HS653-01	Hydraulic for MT-643/644/653 6 Range - Side Mount .....	49
S-HS740-01	Hydraulic for HT-740 6 Range - Side Mount .....	50
S-HS750-01	Hydraulic for HT-754 7 Range - Side Mount .....	51
S-HS540-01	Hydraulic for AT-540 6 Range - Side Mount .....	52

### Transmission Station - Air

S-AS654-01	Air for MT-654 7 Range - Side Mount .....	53
S-AS653-01	Air for MT-643/644/653 6 Range - Side Mount .....	54
S-AS750-01	Air for HT-754 7 Range - Side Mount .....	55
S-AS740-01	Air for HT-740 6 Range - Side Mount .....	56
S-AS540-01	Air for AT-540 6 Range - Side Mount .....	57

### Shifter Assembly

S-SB6-61A	Hydraulic for MT-643/644/653 6 Range - Side Mount .....	58
S-SB7-67A	Hydraulic for MT-654 7 Range - Side Mount .....	59
S-SB7-78A	Hydraulic for HT-740/754 6/7 Range - Side Mount .....	60
S-SB6-73A	Hydraulic for AT-540 6 Range - Side Mount .....	61

### Miscellaneous

RKIT-016	Linkage Kit, Side Mount .....	62
----------	-------------------------------	----

# Typical Layout of Dual Control System

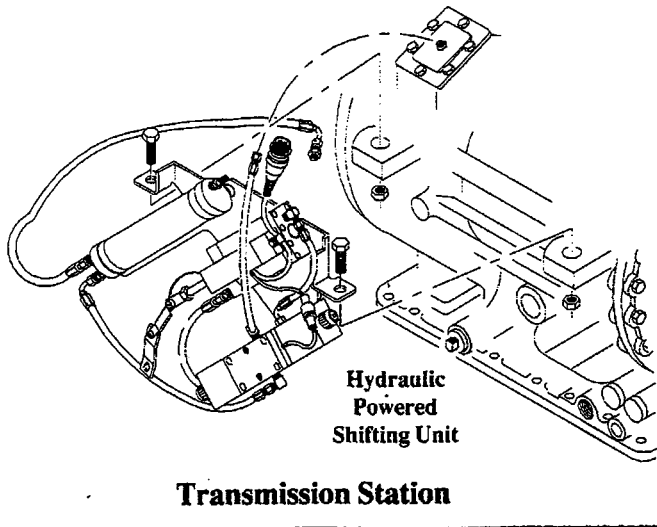
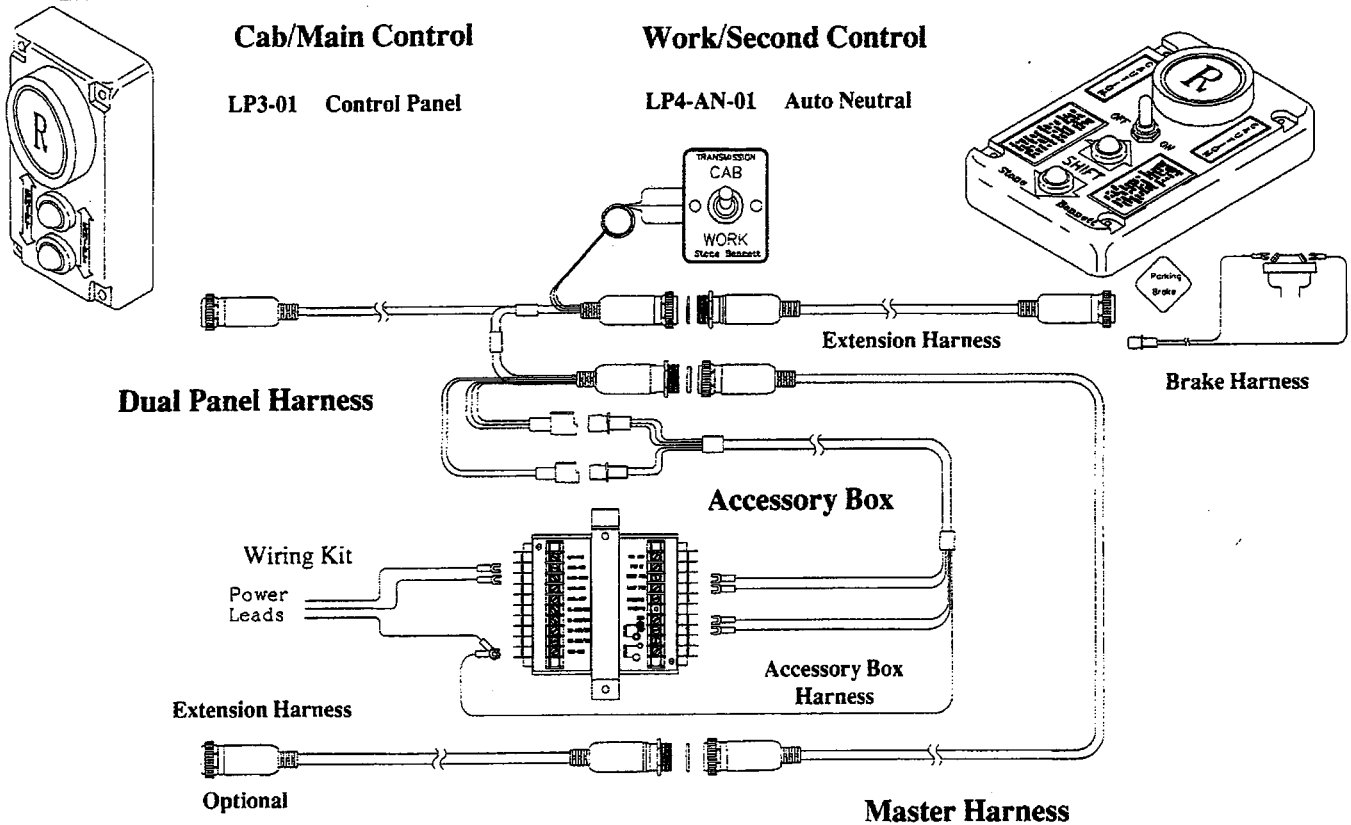

## • Transmission Station

The shifting unit bolted to side of automatic transmission housing is available in two basic versions. One is powered by air pressure from vehicle air system. The other is powered by hydraulic oil pressure from the automatic transmission.

Air powered units are much easier to maintain, lighter in weight, easier to install and perform extremely well in cold climates. Shift cycle time is 4-5 times faster than hydraulic powered units.

Hydraulic units do not experience the "immediate" impact during a shift as the air powered units, thus the life of internal components (in most cases) extend a number of years beyond the expected life of air componentry. Secondly, the internals of shifter are much less likely to become contaminated as fluids inside transmission are usually cleaner and maintained much better than vehicle air systems.

Typical applications for the Extension Harness are:

- Used to extend the Master Harness beyond 45 feet without ordering a special Master from factory.
- Used to break the harnessing for those installations where the cab of vehicle is wired separately before joining with chassis. Either harness, Master or Extension, may reside in any sequence so long as one Master Harness exists between Transmission Station and Panel Harness.
- Used to connect any control station to Single or Dual Panel Harness.

Available in 9 standard lengths in increments of two (2) feet to 18 feet. Order as needed from Back Page.

Vibration Kits are offered for all models and should be used in applications where excessive engine vibrations could continually shake the shifting device.

Cold Weather Kits are offered for hydraulic powered models to provide heated transmission fluid to shifter at all times. They are recommended for all operating climates of sustained 32 degrees F or below. Otherwise, slow shift cycles could occur.

# Typical Layout of Single Control System

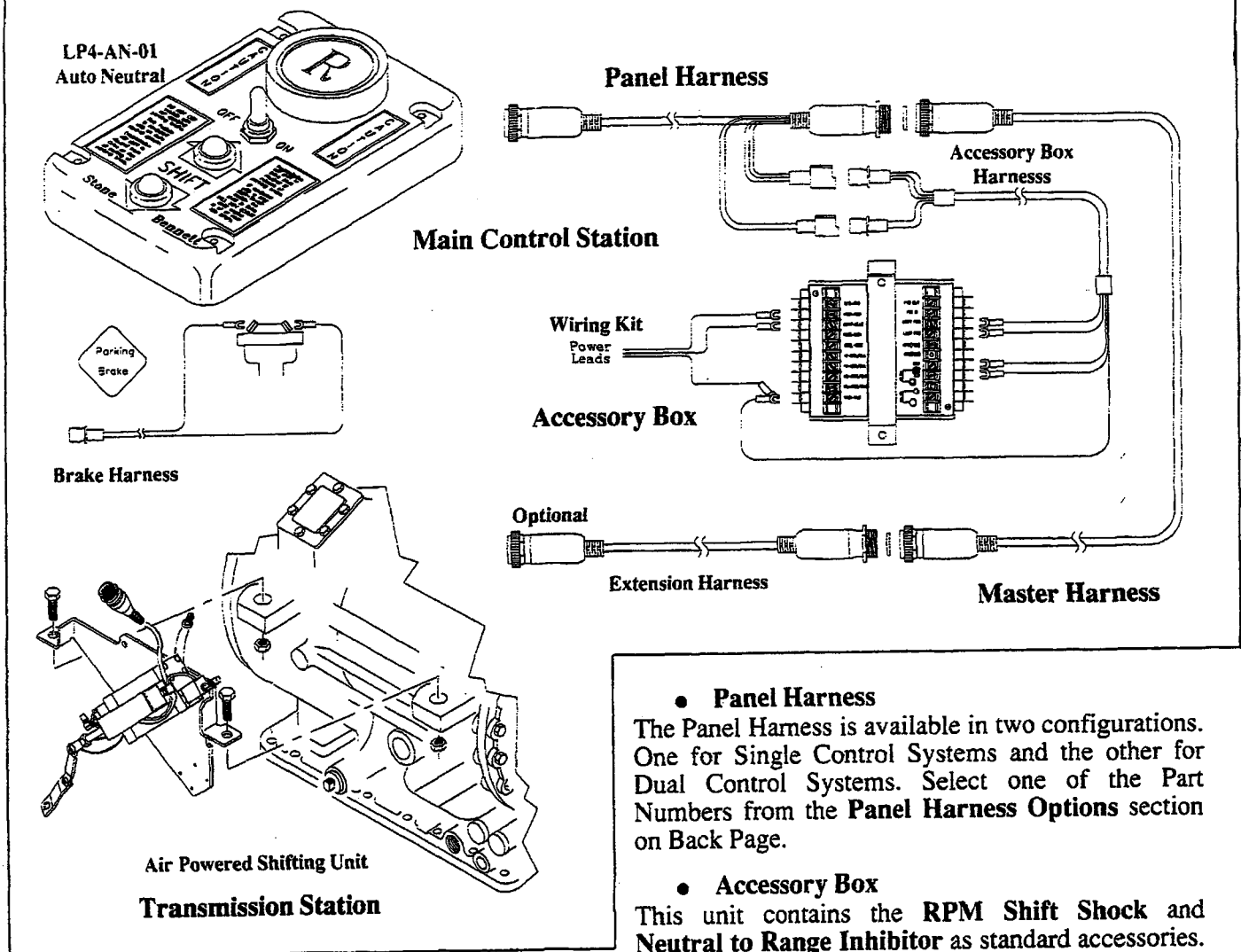

## Selecting Components

All components except the Panel Harness may be used in either a Single or Dual Control System.

### • Cab or Main Control Station

This control may be either the small LP3-01 Series style unit or the LP4-AN-01 Series, a larger body containing PCB circuitry to perform the Auto Neutral shifting features. Both units contain a "sunshine readable" LED display with light sensor to dim the display in night operations. Select one of the Part Numbers from the **Control Options** section on Back Page to serve as the Main Control Station..

### • Work or Secondary Control Station

Use any control style as above. However, the Auto-Neutral shifting with Work Brake only works from the Station where unit is located and only when that Station is activated by the Station Select Switch.

### • Panel Harness

The Panel Harness is available in two configurations. One for Single Control Systems and the other for Dual Control Systems. Select one of the Part Numbers from the **Panel Harness Options** section on Back Page.

### • Accessory Box

This unit contains the **RPM Shift Shock** and **Neutral to Range Inhibitor** as standard accessories. Options include various levels of PTO pump controls plus an option for a Relay circuit to close when Transmission is indicating Reverse Range, for control of backup horns, lights and the like. Select one of the Part Numbers from the **Accessory Box Options** section on Back Page. Do not forget to select the proper **Wiring Kit** to connect Accessory Box to vehicle ignition system.

### • Master Harness

This harness is used to connect the Panel Harness to shifting unit at Transmission Station. Note the same connector is used at both ends. The Master Harness is available in 9 standard lengths in increments of five (5) feet to 45 feet. Longer lengths are available via special order from factory.

### • Extension Harness

This harness is different from Master Harness in that it has opposite mating connectors at each end. It can be inserted anywhere within the harnessing scheme where a mating 16-Pin round connector is used.



# Bennett Controls



Tel: 734-416-8000  
Fax: 734-416-9113  
www.froudehofmann.com

45225 Polaris Ct.  
Plymouth, MI. 48170

## Installation Bulletin

# 14A-653Hxx-02

to Allison Automatic Models  
MT643/644/647/653

B-89 Shift System: Electric/Hyd/Electric with LP4 Auto Neutral Control, Neutral-Off, RPM Shift-Shock

Pub: I1463H02 12-89

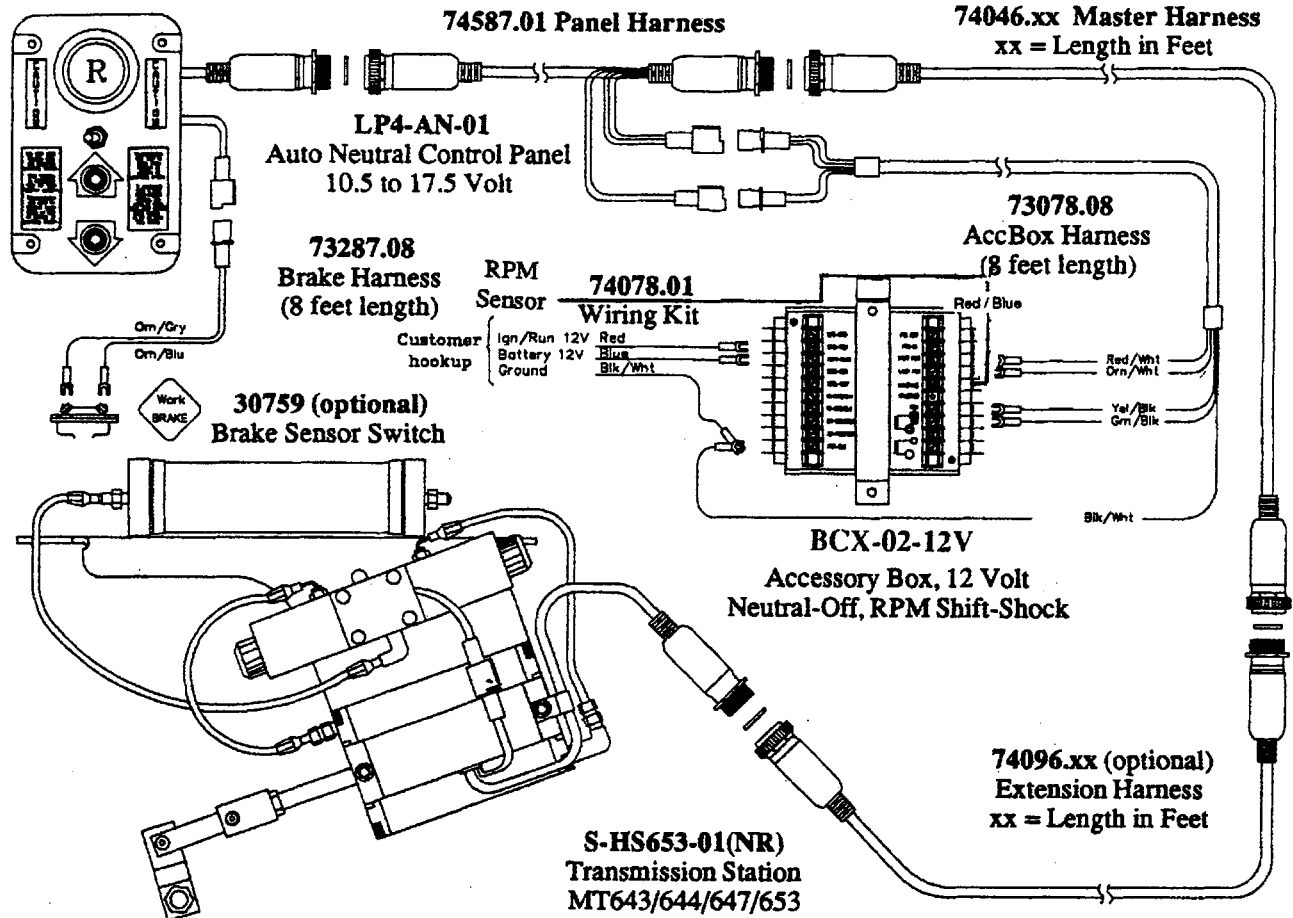

### Installation Bulletins Required

Additional bulletins required for complete installation, adjustment and test of all components within this Shift Control System are:

Control Panel: LP4-AN-01

Accessory Box: BCX-02-12V

Transmission Station: S-HS653-01

Please review all bulletins before attempting any actual installation. Each electrical wire in the system has a specific purpose, so pay strict attention to wiring connections and make double sure all connections are tight after installation!

### Features of Shifting System

**Operator Station - Flush Mount LP4 style control with internal PC Board for Auto-Shifting to and from Neutral Range at setting of Park or Work Brake. Unit utilizes a 16-segment LED Display, two sealed push buttons with neoprene covers and a 16-Pin round molded connector. Displays individual ranges R N D 3 2 1.**

**Harnessing - Brake Harness uses a 2-Pole connector for attachment of Auto Neutral control to Brake Sensor Switch. Panel Harness is weather sealed 16-Pin round connectors with a 2-Pole and a 4-Pole connector to interface with a mating harness to Accessory Box. Master Harness is weather sealed both ends with 16-Pin round connectors. Extension Harness (if used) is of same construction as Master Harness.**

**RPM Shift-Shock Eliminator - Located in Accessory Box. Uses alternator of vehicle to sense engine RPM's and will not allow operator to shift out of Neutral range unless engine is at or near idle speed. Also referred to as Neutral-Lockout or Neutral-To-Range Inhibitor.**

Features Continued	Installation Continued
<p><b>Neutral-Off Module</b> - Located in Accessory Box protects the neutral-start feature of the vehicle. If ignition is turned OFF while transmission is in any other range than Neutral, the engine and all accessories remain ON until operator shifts transmission to Neutral at which time the shift system, engine and accessories will automatically shut OFF.</p> <p><b>Transmission Station</b> - Uses hydraulic fluid from pressure port of transmission to power the shifting unit. An Accumulator tank is located atop mounting bracket to hold 10-15 reserve shifts in the event engine stalls, shutting off flow of fluid to shifter. These reserve shifts allow operator to shift transmission back to Neutral range for re-starting of engine.</p> <p>Shifting of transmission is controlled by an electric - hydraulic valve located on side of mounting bracket. Transmission fluid flows through the Accumulator to a Sub-Plate under the valve, whereby the valve selects proper porting of fluid to shifter in response to an electric signal coming down the harness from operator's station.</p> <p><b>Communication</b> - All range signals to Control Panel from Transmission Station and all shift commands from Control Panel to valve at Transmission Station are electric. All wiring is located in sealed, jacketed harnessing with all-weather 16-Pin molded connectors.</p>	<p style="text-align: center;"><u>Installation of Panel Harness and Accessory Box</u></p> <ol style="list-style-type: none"> <li>1. Apply a light coat of grease to pins inside connector and connect the Panel Harness 74587.01 to rear of Control Panel.</li> <li>2. Install Accessory Harness 73078.08 from connectors on Panel Harness to Accessory Box location.</li> <li>3. Use Installation Bulletin BCX-02-12V and install Accessory Box, Wiring Kit 74078.01 and the wire leads from Accessory Harness.</li> </ol> <p style="text-align: center;"><u>Install Transmission Station</u></p> <p>Use Installation Bulletin S-HS653-01 and mount all items to transmission housing.</p> <p style="text-align: center;"><u>Install Master &amp; Extension Harness</u></p> <p>The Extension Harness is normally used in OEM assembly lines where the Cab and Chassis are assembled in different locations and merged together in final assembly of vehicle. It is not required for general installation or for field retrofit unless user, for some reason, needs a break in harness from Panel Harness to Transmission Station.</p>
<p style="text-align: center;"><b>Installation Instructions</b></p> <p>Read all instructions carefully and if you have any questions or need installation assistance, please give us a call or contact your local distributor.</p> <p style="text-align: center;"><u>System Layout</u></p> <p>Layout the Control Panel, Accessory Box, Panel Harness and Master Harness to get a feel for how the units will actually fit in the vehicle. If possible, try to keep all components within the wire lengths supplied in Kit . When selecting a mounting location for the Control Panel, keep in mind overall operator needs such as visual angles to see the LED Display at all times, movement of hands and arms to reach the Push Buttons for shifting, etc. Try to locate harnessing in such a manner that a little slack is available at the ends of all wiring for easy disconnect and servicing in future years.</p> <p style="text-align: center;"><u>Installation of Control Panel</u></p> <p>Use Installation Bulletin LP4-AN-01 and mount the Control Panel, Brake Harness and Brake Sensor Switch.</p>	<p>If Extension Harness 74096.xx (where xx = Length in Feet) is being used, it makes no difference in what sequence the Extension is installed in relation to the Master Harness 74046.xx (where xx = Length in Feet).</p> <ol style="list-style-type: none"> <li>1. Run Master Harness (and Extension Harness if used) from Panel Harness at Operator's Station to 16-Pin Round Connector on shifting unit at Transmission Station.</li> </ol> <p>If possible, leave ample slack at both ends of harness. Make sure the harness is tightly secured and not pulled across any sharp edges or resting against hot surfaces such as engine manifolds, etc. Check that moving parts such as fan blades, latches, and hydraulic arms cannot cut or sever the harness during normal operation of the vehicle.</p> <ol style="list-style-type: none"> <li>2. Apply a light coat of grease to pins inside the Connectors before joining the harnesses. Tie down all loose ends and bends.</li> </ol> <p><b>You are now ready for Operations Test and Final Adjustments.</b></p>

## Operations Test and Final Adjustments

### Operation of Control Panel with Auto Neutral Shifting in OFF Position.

With the Auto Neutral Shifting feature in the OFF position, this control panel becomes a standard Bennett type control with single "up-down" shifting where only one adjacent range can be selected at each push of a button. A shift is made by pushing and holding down one of the Buttons until the existing Range Display goes OFF and the next adjacent Range Display comes ON. Another shift cannot be made (in either direction) until the button is released.

Pushing the Top Button (nearest LED Display) will cause a shift to the next adjacent Range toward the top of Shift Legend R to N to D to 3 to 2 to 1.

Pushing the Bottom Button will cause a shift to the next adjacent Range toward the bottom of Shift Legend 1 to 2 to 3 to D to N to R.

## Caution

### Operation of Control Panel with Auto Neutral Shifting in ON position.

When the Auto Neutral Shifting feature is "ARMED" in the ON position, this control panel will automatically perform a shift of the transmission from one range to another as follows:

When transmission is either in Drive Range or in Reverse Range and the Park Brake is ON (or set to the ON position), the transmission will automatically shift to Neutral Range.

When the transmission is in Neutral Range and the Park Brake is released from the ON position to the OFF position, the transmission will automatically shift to the forward Drive Range.

If the shift system is equipped with an RPM Shift Shock device or an RPM Neutral-to-Range Inhibitor, the automatic shift from Neutral Range to Drive Range will not occur until the engine RPM has met the requirement for a shift.

### LED Display

Auto-Neutral On / Off

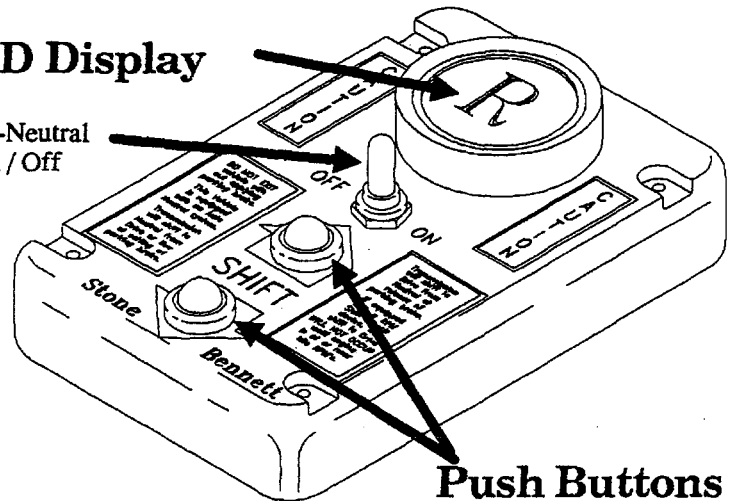

Push Buttons



## Caution

Using Push Buttons with Auto Neutral Shifting in ON Position

When using the Push Buttons to access the lower forward ranges of First (1), Second(2) and Third(3) the operator of vehicle must be aware that Auto Neutral shifting will not occur within these ranges and the Control Panel will not react to the setting or the release of Park Brake.

However, when the Park Brake is in the ON position and the Push Buttons are used to access Drive Range (D) from the Third Range (3) position,

an automatic shift to Neutral Range will occur at release of Push Button

because Park Brake is in the ON position and the transmission is reading Drive Range.

When the Park Brake is in the ON position and the Push Buttons are used to shift from Neutral Range to Reverse Range or from Neutral Range to Drive Range

an immediate automatic shift back to Neutral range will occur at release of Push Button

because the Park Brake is in the ON position

### Shift Legend

1

First Forward Range

2

Second Forward Range

3

Third Forward Range

D

Drive Range

N

Neutral Range

R

Reverse Range



# Caution

Do not attempt to adjust Shifter at Transmission with the engine running or while the vehicle is in operation.

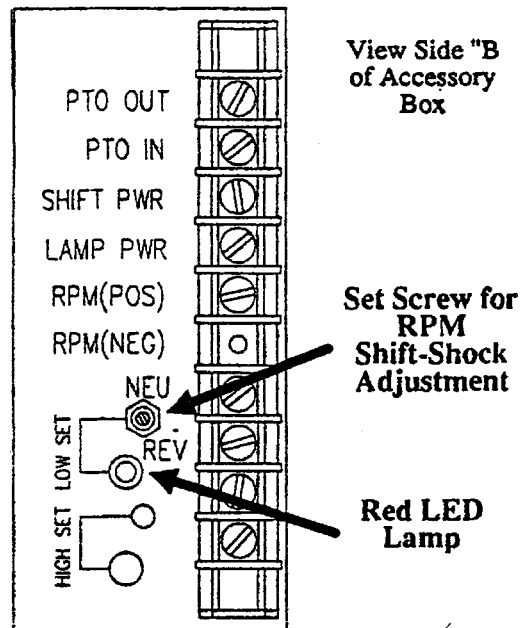
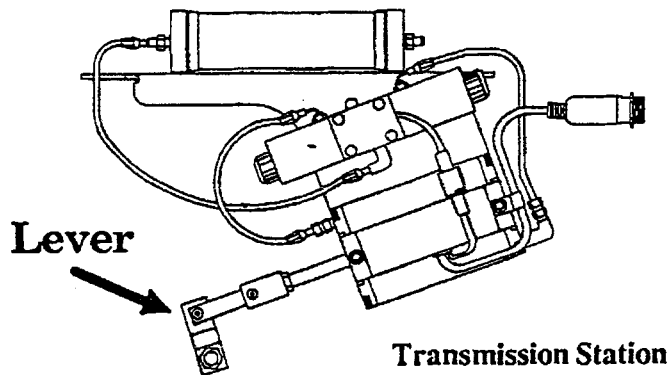

**Note:** Final check and test procedures below require all shift system components to be installed and ready for operation.

## Test Basic Shifting System

1. If transmission is not in Neutral, move the Range Selector at transmission to Neutral position in order to engage the "Neutral-Start" circuit of the ignition system.
2. Turn Auto-Neutral toggle switch on the control panel to its OFF position.
3. Turn ignition to ON position. Do not start vehicle at this time.
4. The Neutral Range "N" should appear on LED Display.

If not, check all power connections going into Accessory Box. Check all 16-Pin connectors for proper installation. Check adjustment of Shifter at transmission to make sure it is in Neutral range.

5. Set all brakes and start engine.

Allow engine to warm up and make sure air system is fully charged and properly working before continuing any test of shifting system.

6. Refer to Installation Bulletin BCX-02-12V and adjust RPM Shift-Shock setting.

If problems arise with a blinking LED lamp on Accessory Box or the Display on Control Panel is blinking, the Shifter at transmission is most likely out of adjustment or loose and not sending a good, solid Neutral signal to the control panel.

7. Using Control Panel, slowly shift transmission through all ranges.

Each Range display should be bright, steady and no blinking. If Display does not function correctly, check Shifter at transmission in Step 8 below before trouble shooting any wiring.

8. Using Control Panel, slowly shift transmission through all ranges. Engage and hold the push button 2-3 seconds when selecting each new range. If Shifter at transmission is correctly adjusted, the Lever and linkage of Shifter should not move when Button is released. Shut down engine and readjust Shifter if required.

## Test Neutral-Off Feature of Ignition

Check Neutral-Off feature by shifting the transmission into Drive or Reverse. Turn ignition to OFF position. The engine and all accessories should remain ON even though the ignition is turned OFF.

If not, check the BLUE wire coming from the Accessory Box that is connected to BATTERY. There should be electrical power in this wire at all times, regardless of ignition switch position.

If engine remains running, use the push button and shift transmission to Neutral Range where the engine and all accessories should go OFF, including all lighted displays on control panel.

## Test Auto Neutral Control

Refer to Installation Bulletin LP4-AN-01 and conduct all testing procedures for Auto Neutral.

Final Test and Adjustments are Complete.



Tel: 734-416-8000  
Fax: 734-416-9113  
www.froudehofmann.com

45225 Polaris Ct.  
Plymouth, MI. 48170

- Description: Accessory Box 12-Volt, RPM Shift Shock, Neutral-Off Module

Pub: IACX0212 12-89

### Wiring Kit 74078.01

RPM Snsr Red/Blu  
Ign/Run 12V Red  
Battery 12V Blue  
Ground Blk/Wht

This wire might be solid Black in some Kits.

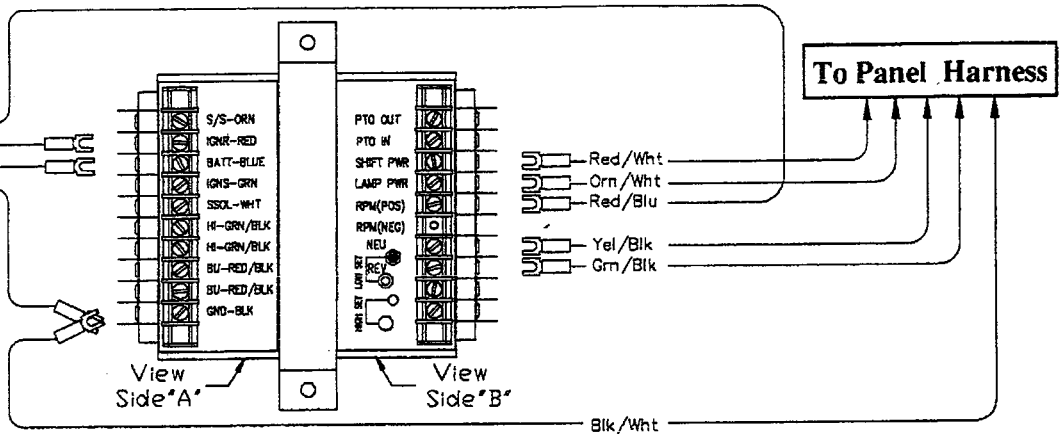

### General Installation Instructions

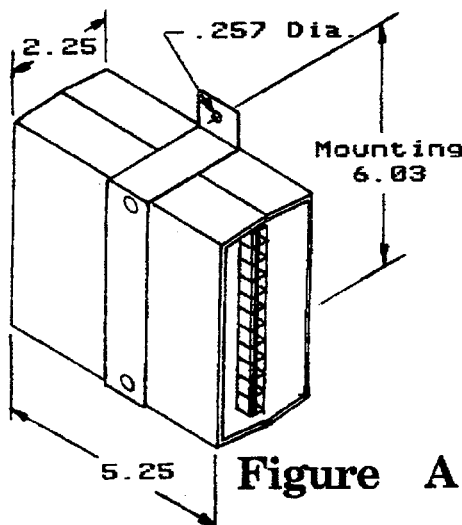

Figure A

#### Features Included in Accessory Box

**Neutral-Off Module** - Protects the neutral-start feature of the vehicle. If ignition is turned OFF while transmission is in any other range than Neutral, the engine and all accessories remain ON until operator shifts transmission to Neutral at which time the shift system, engine and all accessories will automatically shut OFF.

**RPM Shift-Shock Eliminator** - Uses alternator of vehicle to sense engine RPM's and will not allow operator to shift out of Neutral range unless engine is at or near idle speed. Also referred to as Neutral-Lockout or Neutral-To-Range Inhibitor.

#### Mounting

Locate Accessory Box in protected area of vehicle, away from direct water flow or steam cleaning where direct heat will not exceed 140 degreesF and protected from direct impact. Ideal location is "under-dash" or "under-cover" type mounting to prevent objects coming into contact with the open wiring at each end of Box. Drill mounting holes as shown in Figure A. It may be easier to mount the Box after all wiring and adjustments are complete. The RPM setting for Shift-Shock will require access to Side B of box during final check procedures. Mounting hardware not supplied with kit.

#### Connect Wiring Kit to Accessory Box

1. Connect Black ground wire from Wiring Kit 74078.01 to GND-BLK terminal on SIDE "A" of Accessory Box. Connect other end of wire to direct battery ground as shown in Figure B, if possible. Chassis grounds such as support brackets or sheet metal should not be used. The Box cannot and will not operate correctly with poor ground connections.

### Figure B

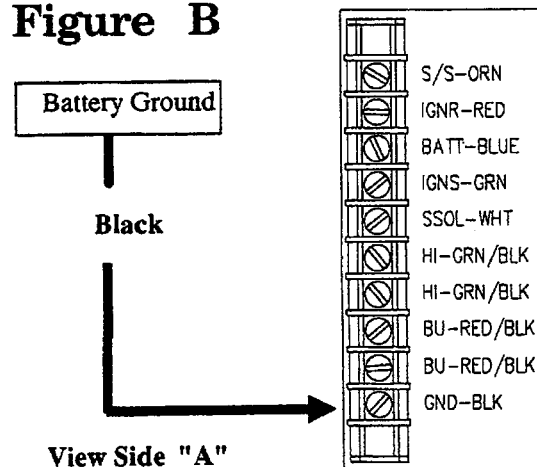



Tel: 734-416-8000  
Fax: 734-416-9113  
www.froudehofmann.com

45225 Polaris Ct.  
Plymouth, MI. 48170

12/24-Volt, Flush Mount, LED Display, Sealed Push Buttons, 16-Pin Pigtail Connector

Pub: ILP30101 12-89

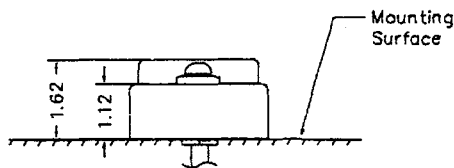

Front View

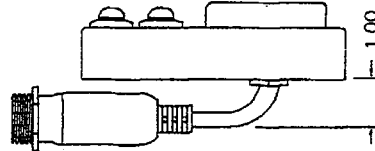

Side View

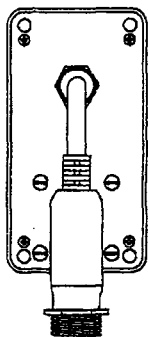
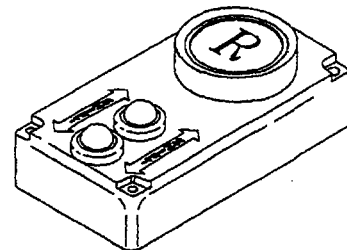

Bottom View

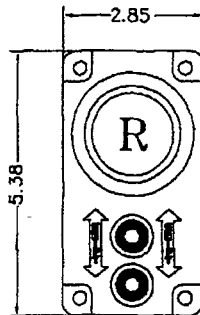

Top View

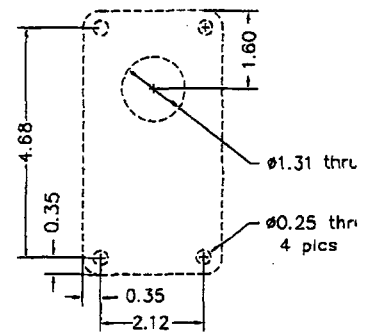

Mounting Dimensions

### Installation Instructions

1. Layout the Control Panel and connecting harness to get a feel for how the units will actually fit in the vehicle.

**Keep in mind the angle at which the operator will have to view the LED Display, hand and arm movement to reach the Buttons, etc.**

**The pigtail on rear of Control Panel can be directed a full 360 degrees to mate with 16-Pin Connector on Panel Harness.**

**Try to leave a little slack in the harness for easy disconnect and servicing.**

2. Choose a sturdy mounting location such as a thick dash panel or frame member. Thin metal or plastic panels are not recommended. Leverage created by pushing the buttons can cause heavy loads to be exerted to mounting surface.

3. Using hole dimensions as shown above or using the Control Panel as a template, drill mounting holes as required. Clearance holes in Control are 0.25 inch diameter. Mounting screws not supplied with kit.

4. You can mount the unit at this time or wait until all other components are in place and ready for test.

## LED Display of Transmission Ranges

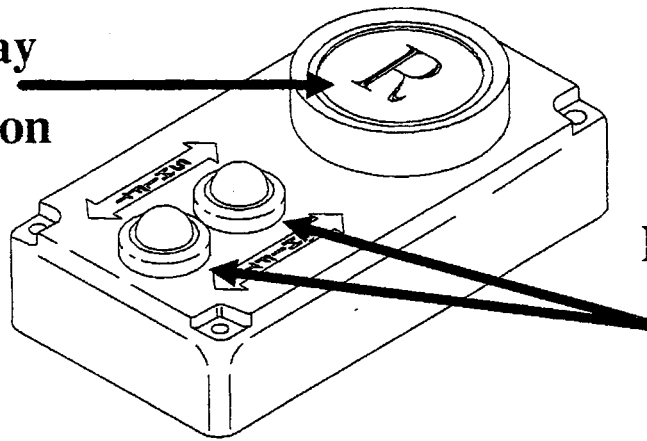

Push Buttons  
with  
Neoprene  
Domes

### How the Control Panel Works

The Push Buttons send power (when engaged) to a set of solenoids at Transmission Station to cause an "upshift" or "downshift" of the range lever to its next, adjacent range position.

As the range lever at Transmission moves from one range position to another, the display on Control Panel will change to the new position accordingly.

The display itself is made up of 16 individual LED (Light Emitting Diode) segments that are controlled by a PC Board to form characters being displayed upon the panel.

The PC Board and Display are reacting to a sliding switch inside the Transmission Station that sets a "chassis" ground with contacts according to the position of shaft and lever linkage.

As a shift is being made, the sliding switch moves toward the next position, breaking contact about half way between ranges and the existing range display goes OFF. There is a .050 inch gap between each range where the switch is not making contact. The display remains OFF until the switch engages the next contact position, closing a circuit to another port in the PC Board, which in turn "light up" the proper LED segments to form a new range character.

Therefore, the Display is telling the operator what has happened before, during and after a shift at the transmission.

### Operating Instructions

This control is a single "up-down" shifting unit where only one adjacent range can be selected at each push of a button.

A shift is made by pushing and holding the upper or lower Push Button until the Transmission Station has moved the range lever to next adjacent range. A successful shift is complete when the Display changes and remains in the next range character.

Another shift can be made by releasing the Button and again pushing one of the buttons for desired direction of shift. Continually pushing and releasing the same button will move the range selector at transmission in the same direction until the last selectable range has been achieved.

The operator has to hold the Push Button in its "engaged" position until the shift is complete. A short surge of power by simply slapping the button might not send enough electrical power to move the range lever at Transmission Station. When this happens the existing range character will come back ON, letting the operator know that a shift was not completed.

**Pushing the upper or forward button** will cause a shift to the next adjacent range away from Reverse toward upper Forward ranges.

**Pushing the lower or reward button** will cause a shift to the next adjacent range away from upper Forward ranges toward Reverse.

Shifting Unit at  
Transmission Station

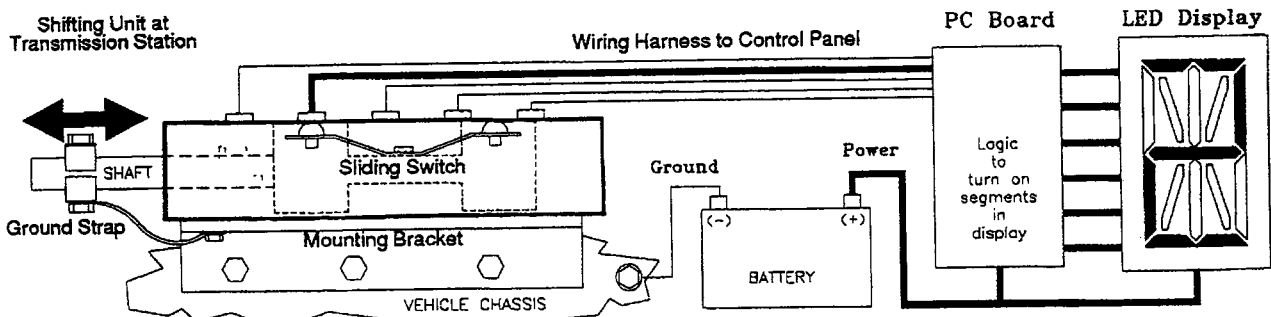

# Caution

Do not attempt to adjust Shifter at Transmission with the engine running or while the vehicle is in operation.

## LED Display

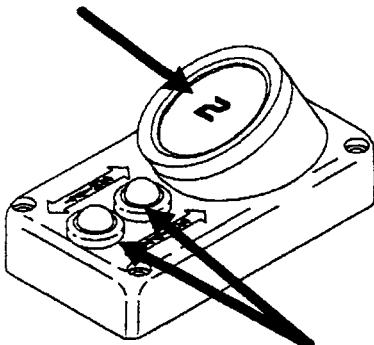

### Operation of Control Panel

This control is a single "up-down" shifting unit where only one adjacent range can be selected at each push of a button. A shift is made by pushing and holding down one of the Buttons until the existing Range Display goes OFF and the next Range Display comes ON. Another shift cannot be made (in either direction) until the button is released.

## Push Buttons

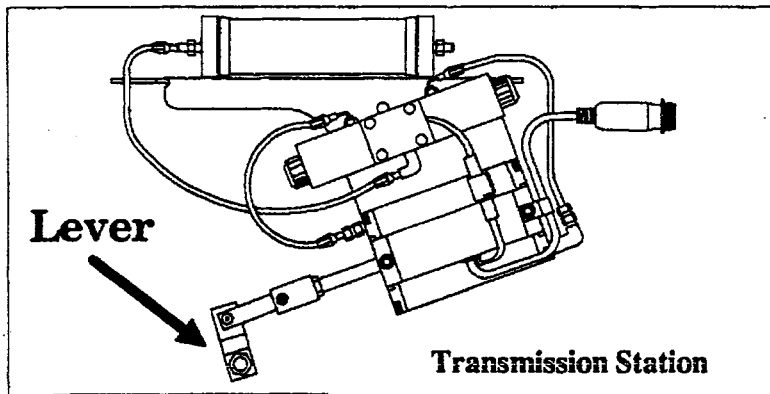

Lever

Transmission Station

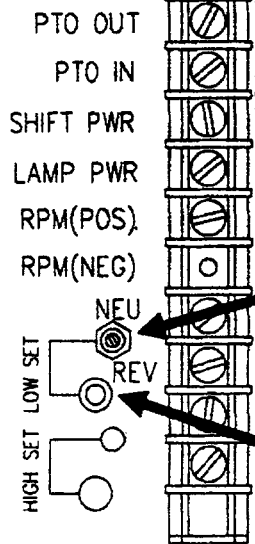

Set Screw for RPM Shift-Shock Adjustment

View Side "B" of Accessory Box

Red LED Lamp

Note: Final check and test procedures below require all shift system components to be installed and ready for operation.

1. If transmission is not in Neutral, move the Range Selector at transmission to Neutral position.

2. Turn ignition to ON position. Do not start vehicle at this time.

3. The Neutral Range "N" should appear on LED Display. If not, check all power connections going into Accessory Box. Check all 16-Pin connectors for proper installation. Check adjustment of Shifter at transmission to make sure it is in Neutral range.

4. Set all brakes and start engine.

5. Refer to Installation Bulletin BCX-02-12V and adjust RPM Shift-Shock setting. If problems arise with a blinking LED lamp on Accessory Box or the Display on Control Panel is blinking, the Shifter at transmission is most likely out of adjustment and not sending a good, solid Neutral signal.

6. Using Control Panel, slowly shift transmission through all ranges. Each Range display should be bright, steady and no blinking. If Display does not function correctly, check Shifter at transmission in Step 7 below before trouble shooting any wiring.

7. Using Control Panel, slowly shift transmission through all ranges. Engage and hold the push button 2-3 seconds when selecting each new range. If Shifter at transmission is correctly adjusted, the Lever and linkage of Shifter should not move when Button is released. Shut down engine and readjust Shifter if required.

8. Continue adjustments until each Range Display at Control Panel is correctly lit for each range position and burning with a bright, steady glow (engine running), and Shift-Shock is set at proper RPM level for normal vehicle operation.

Final Test and Adjustments are complete.

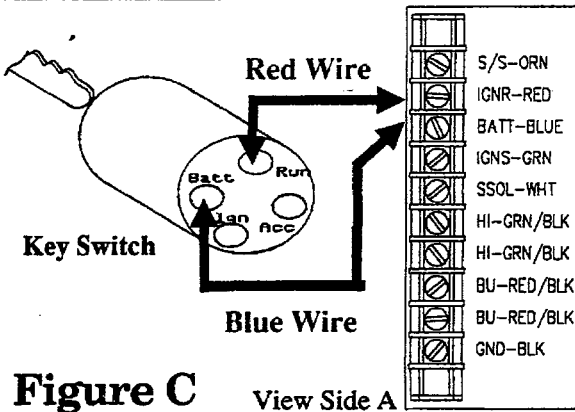

**Figure C** View Side A

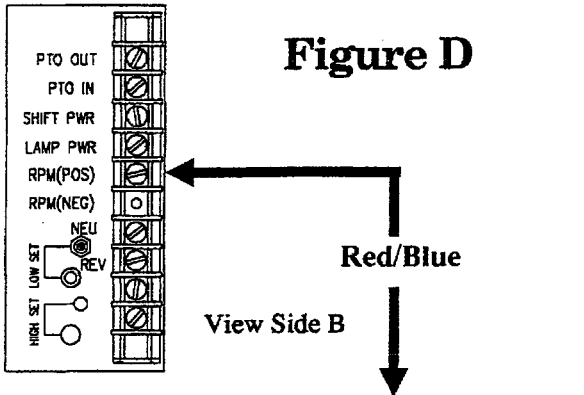

**Figure D**  
View Side B  
To "R" terminal of vehicle alternator as shown by the arrows below.

2. Connect the main power wire (Red) from Wiring Kit 74078.01 to IGNR-RED terminal on SIDE "A" of Accessory Box. Connect other end of wire to the RUN side of the Key Switch as shown in Figure C. If circuit breakers are used instead of a "direct connect" to Key Switch, then cut off the fuse assembly supplied with wire and connect to a 10 AMP breaker. The Red wire should provide power to Accessory Box any time Key Switch is in the ON position.

3. Connect the Neutral-Off power wire (Blue) from Wiring Kit 74078.01 to BATT-BLUE terminal on Side "A" of Accessory Box. Connect other end of wire to constant battery power BATT of Key Switch as shown in Figure C. If circuit breakers are used instead of a "direct connect" to Key Switch, then cut off the fuse assembly supplied with wire and connect to a 10 AMP breaker. This Blue wire should provide power to Accessory Box at all times.

4. Connect the RPM-Sensor wire (Red/Blue) from Wiring Kit 74078.01 to RPM(POS) terminal on Side "B" of Accessory Box. Connect other end of wire to the "R" terminal of vehicle alternator as shown in Figure D. The "R" terminal is the AC output terminal of the alternator and should read about half (6-7 Volts) of normal output voltage (12-14 Volts). If at all possible, try to install Red/Blue wire to a terminal on the alternator that does not have other accessories attached. The Accessory Box is designed to handle surges and interference on the line; but if you have a choice, install the wire to a lone terminal.

Make sure all connections at Accessory Box are tight. Tie down all wiring and loose ends.

Note: The Red/Blue wire is a special high temperature (105C) for engine compartments. When mounting, be sure to keep clear of exhaust manifolds, heat exchangers, etc.; and do not pull or stretch wire across sharp edges or corners. Make sure all connections at alternator are tightly connected and weather sealed.

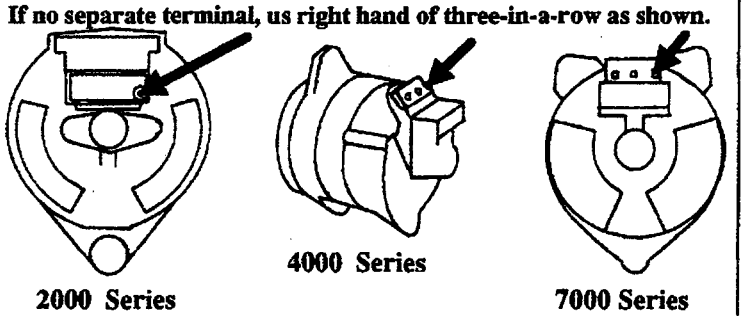
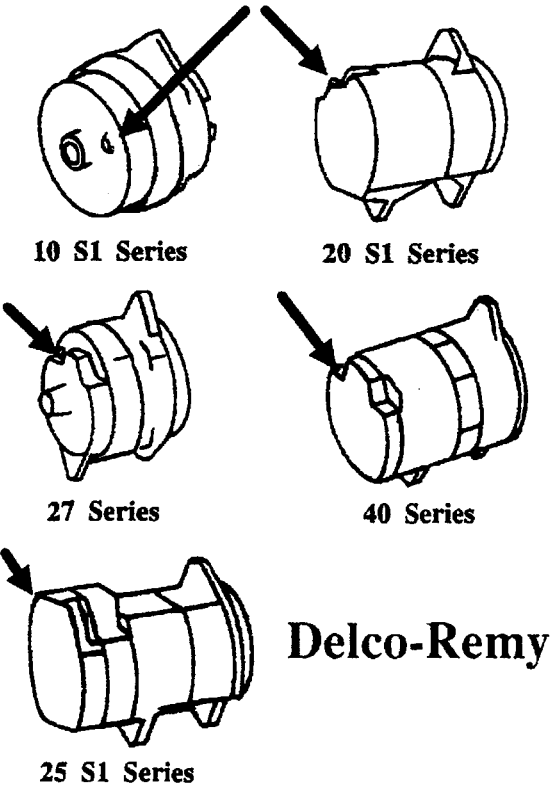

**Leece - Neville**

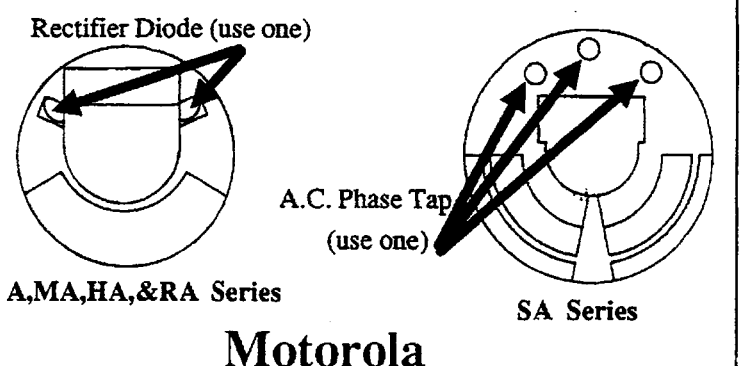

### Connect Wiring from Panel or Led Style Harness

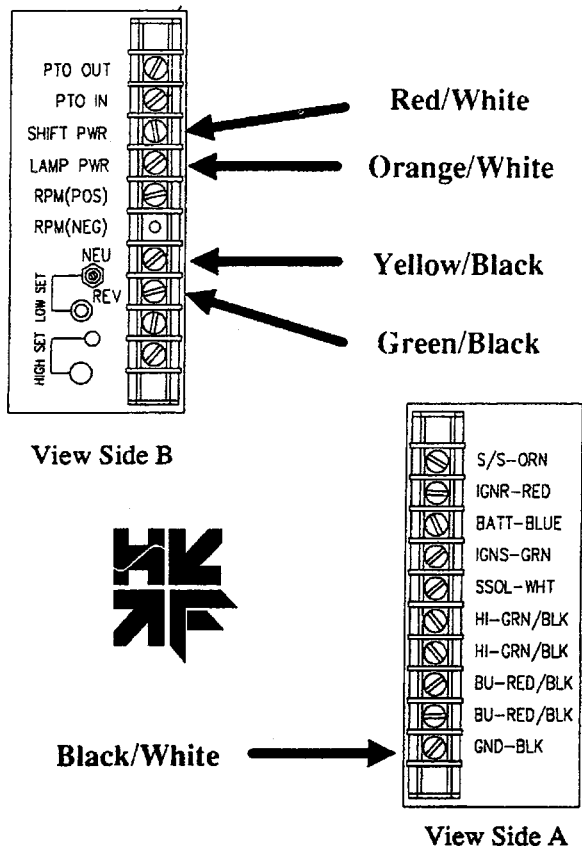

1. Connect Red/White wire from harness to **SHIFT PWR** terminal located on Side "B" of Accessory Box. This wire supplies shift power (12 volts) from the Accessory Box to switch at Control Panel when Shift-Shock Eliminator circuit is closed and okay for operator to shift transmission out of Neutral Range. Otherwise there will be no power in the line for shifting.
  2. Connect Orange/White wire from harness to **LAMP PWR** terminal located on Side "B" of Accessory Box. This wire supplies power (12 Volts) from the Accessory Box to all lights, LED's, relays and circuit boards throughout the remainder of shifting system.
  3. Connect Yellow/Black wire from harness to **NEU** terminal located on Side "B" of Accessory Box. This wire carries a "Chassis Ground" signal from Transmission Station into the Accessory Box when transmission is in Neutral Range.
  4. Connect Green/Black wire from harness to **REV** terminal located on Side "B" of Accessory Box. This wire carries a "Chassis Ground" signal from Transmission Station into the Accessory Box when transmission in Reverse Range.
  5. Connect Black/White wire from harness to **GND-BLK** terminal on Side "A" of Accessory Box. This wire carries common battery ground into the shifting system for circuit boards and relays at the Control Panel or within the harnessing.
- Make sure all connections at Accessory Box are tight. Tie down all wiring and loose ends..

### Final Test and Adjustments (RPM Threshold)

**Note:** The adjustment procedures below require all shift system components to be installed and operating.

1. Set all brakes and start engine. With transmission in Neutral range and engine at idle, look at the Red LED lamp on Side B of Accessory Box (Low Set) and see if it is lit. Boxes are normally sent from factory set at 450 RPM, so the LED will most likely be OFF during initial start up of engine.
2. If the lamp is OFF, turn Low Set screw clockwise until the Red LED lamp comes ON. If the lamp is ON, turn screw counterclockwise until lamp goes OFF, then slowly turn back clockwise until lamp comes ON. The Shift-Shock threshold is now set at current engine idle speed.
3. Increase engine RPM to level where you desire the threshold to be set for normal operation of vehicle. This is normally 50-100 RPM above "warm" idle.

Keep in mind the "cold" idle condition of engine. Different types of engines have various speeds to warm the engine. Set the shift threshold at level that best fits your "cold idle" conditions.

4. When engine reaches desired RPM, hold throttle steady and turn screw clockwise until Red LED goes OFF. This will be the Shift-Shock threshold to restrict any shifting out of Neutral to any Forward range or to Reverse when engine RPM's are above the threshold setting.
5. Allow engine to return to idle speed. The LED should remain ON. Use Control Panel and shift transmission to any Forward range or to Reverse. The LED should remain ON. Return transmission to Neutral and increase engine RPM's above threshold setting. The LED should go OFF and you should not be able to shift the transmission out of Neutral range.

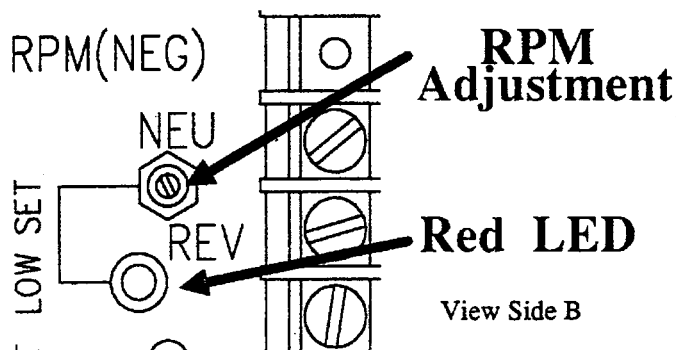

6. If safe conditions permit with engine at idle RPM's, shift transmission out of Neutral range and increase engine speed to above threshold setting. The LED should be ON. Hold engine speed above the threshold and Shift transmission to Neutral. The LED should go OFF and remain OFF until engine speed falls below threshold setting, at which time the LED will return to its ON condition. Setting of Shift-Shock is complete

**Note:** The Red LED will be lit any time the Shift-Shock circuit is passing 12 Volts power out the **SHIFT PWR** terminal on Side "B" of Accessory Box.



Tel: 734-416-8000  
Fax: 734-416-9113  
www.froudehofmann.com

45225 Polaris Ct.  
Plymouth, MI. 48170

Flush Mount, 12-Volt with Auto Neutral Shifting, LED Display, Sealed Push Buttons, 16-Pin Pigtail

Pub: ILP4AN01 12-89

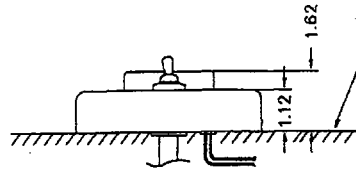

Front View

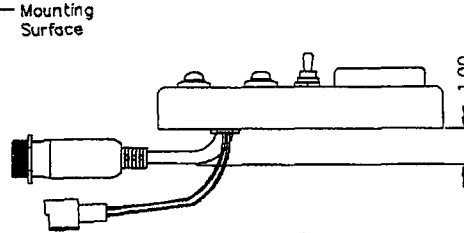

Side View

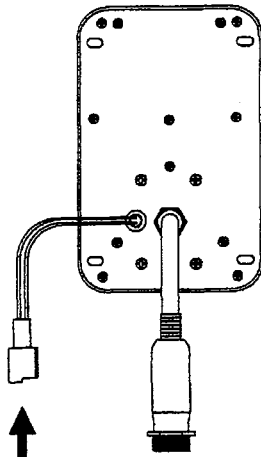
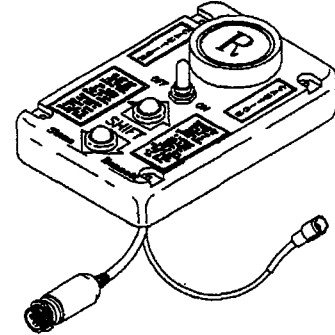

Bottom View

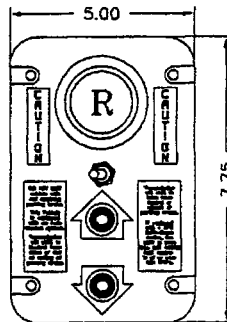

Top View

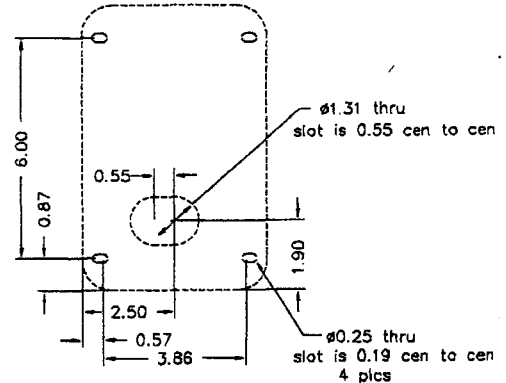

Mounting Dimensions

Brake  
Harness



Parking  
Brake

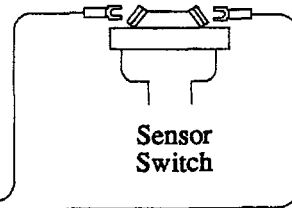

Sensor  
Switch

### Accessories Required

P/N 30759 Air-Brake Sensor Switch  
P/N 72387.xx Brake Sensor Harness  
(where xx = Length in Feet)

## Installation Instructions

**This control panel contains 12-volt circuitry and should not be connected to electrical systems that have operating voltages below 10-volts or above 15-volts.**

This Auto Neutral control panel may be installed to any operator's station (Left, Right, Single or Dual control system) within the B-89 harnessing scheme. It may be used as the only control in a Single Control system, the Main/Street side control in a Dual Control system or as the Work/Curb side control in a Dual Control system.

The function of the Auto Neutral control is to provide

automatic gear selection at the transmission in response to the setting or to the releasing of a Work/Park Brake by the vehicle operator.

In general, when the transmission is in Drive or Reverse Range and the operator sets the brake, the Auto Neutral will shift the transmission to Neutral Range. When operator releases the brake, the Auto Neutral will return the transmission to Drive Range.

The Control Panel contains an ON/OFF toggle switch to activate the Auto Neutral shifting feature. When toggle switch is in the OFF position, the control panel becomes a standard Push Button shifting system.



## Installation Instructions

1. Layout the Control Panel and connecting harnessing to get a feel for how the units will actually fit in the vehicle.

Keep in mind the angle at which the operator will have to view the LED Display, hand and arm movements to reach the push buttons for shifting, etc.

Each of the two pigtail harnesses extending from control can be directed a full 360 degrees. Try to leave a little slack in each harness for easy disconnect and servicing in future years.

2. Choose a sturdy mounting location such as a thick dash panel, engine cowling or frame member.

Thin metal or plastic sheeting are not recommended. Leverage created by pushing the shift buttons can cause heavy loads to be exerted to mounting surface.

3. If mounting to cowling directly above engine, especially the manifolds, make sure proper insulation is residing under cowling to divert as much heat as possible away from bottom of control panel.

The control is rated to -35 to 100C (-31 to 212F). Higher operating temperatures will dramatically decrease the normal operating life of components.

4. Using the hole dimensions as shown on front page or using the Control Panel as a template, drill mounting holes as required. Clearance holes in Control Panel are 0.25 inch diameter. Mounting screws are not supplied with kit.

5. You can mount the LP4-AN-01 at this time but may be easier to connect all harnessing before bolting the unit to vehicle.

### Air-Brake Sensor Switch

A pressure switch must be installed to the Work or Park Brake air system and electrically connected to the Two-Pole connector extending from Auto Neutral control panel. The opening and closing of this switch must be in compliance with the setting and releasing of Brake Applicator system being used.

When brake is in the OFF position, the air pressure sensor switch must be "normally closed" .

The Auto Neutral sends an electric current out one of the wires (in the 2-pole harness) and interprets a return of power in the other wire as the Brake being in the OFF position.

When brake is in the ON position the air pressure sensor switch must be "open" and break the circuit coming from the Auto Neutral control panel.

When the Auto Neutral cannot detect electrical power returning from the switch, it interprets this loss of power as the brake being set to the ON position.

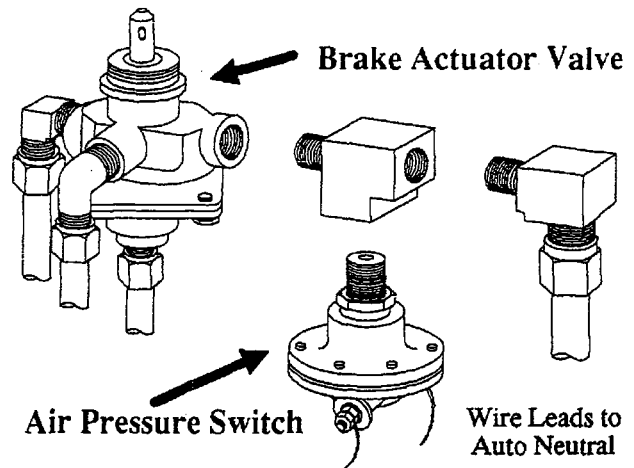

In a Spring Brake Chamber system as shown above, a low air pressure condition exists when the Brake is in its ON position.

A sensor such as a Sealco valve model 8100-B for example, would open the circuit when air pressure gets below 5 PSI. These are available from factory as our P/N 30759 and must be ordered separate from this Shift Kit.

A Pressure type brake system would require just the opposite. When the brake is applied, air pressure is delivered to the the brake chamber and sets the shoes against the wheel drum. The pressure switch in this case has to provide an open circuit (Brake ON) back to the Auto Neutral when the air pressure in brake line is at or near the normal operating pressure of vehicle air system.

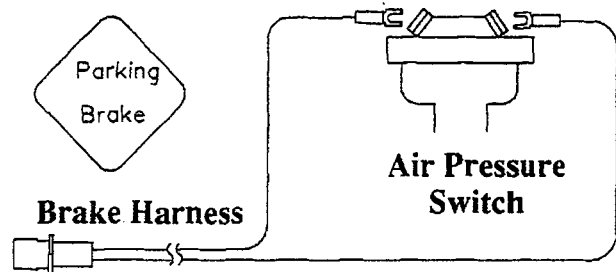

### Install Sensor Switch and Brake Harness

1. Install the proper sensor switch to vehicle Work/Park Brake system.

2. Connect the Brake Sensor Harness P/N 73287 to Sensor Switch. Attach one wire from the harness to one side of the switch and attach the second wire to the other side of switch. It does not make any difference to which of the two ports the wires are attached.

3. If not yet installed, attach Brake Harness to Pigtail connector on Auto Neutral control. Attach Panel Harness to 16-Pin pigtail of Auto Neutral and mount control to vehicle.

## Operating Instructions

### LED Display

Auto-Neutral  
On / Off

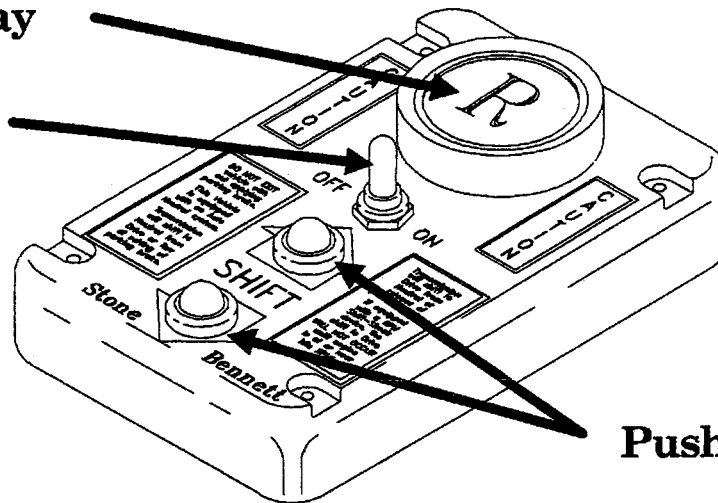

### Push Buttons

## Caution

### Operation of Control Panel with Auto Neutral Shifting in OFF Position.

With the Auto Neutral Shifting feature in the OFF position, this control panel becomes a standard Bennett type control with single "up-down" shifting where only one adjacent range can be selected at each push of a button. A shift is made by pushing and holding down one of the Buttons until the existing Range Display goes OFF and the next adjacent Range Display comes ON. Another shift cannot be made (in either direction) until the button is released.

Pushing the Top Button (nearest LED Display) will cause a shift to the next adjacent Range toward the top of Shift Legend R to N to D to 3 to 2 to 1.

Pushing the Bottom Button will cause a shift to the next adjacent Range toward the bottom of Shift Legend 1 to 2 to 3 to D to N to R.

## Caution

### Operation of Control Panel with Auto Neutral Shifting in ON position.

When the Auto Neutral Shifting feature is "ARMED" in the ON position, this control panel will automatically perform a shift of the transmission from one range to another as follows:

When transmission is either in Drive Range or Reverse Range and the Park Brake is in the ON position (or set to the ON position), the transmission will automatically shift to Neutral Range.

When the transmission is in Neutral Range and the Park Brake is released from the ON position to the OFF position, the transmission will automatically shift to the forward Drive Range.

## Warning

If the shift system is equipped with an RPM Shift Shock device or an RPM Neutral-to-Range Inhibitor, the automatic shift from Neutral Range to Drive Range will not occur until the engine RPM has met the requirement for a shift.

### Using Push Buttons with Auto Neutral Shifting in ON Position

When using the Push Buttons to access the lower forward ranges (other than Drive Range), the operator of vehicle must be aware that Auto Neutral shifting will not occur within these ranges and the Control Panel will not react to the setting or to the release of Park Brake.

However, when the Park Brake is in the ON position and the Push Buttons are used to access Drive Range (D) from these lower Forward Ranges,

an automatic shift to Neutral Range will occur at release of Push Button

because Park Brake is in the ON position and the transmission is reading Drive Range.

When the Park Brake is in the ON position and the Push Buttons are used to shift from Neutral Range to Reverse Range or from Neutral Range to Drive Range,

an immediate automatic shift back to Neutral Range will occur at release of Push Button

because the Park Brake is in the ON position

## Operations Test and Final Adjustments

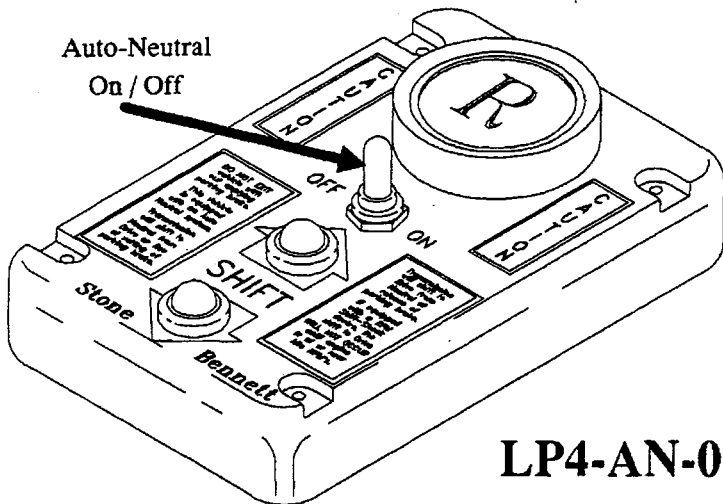

**LP4-AN-01**

## Test Procedures

1. Set foot brake, set park brake, start engine and turn toggle switch of Auto Neutral control to the ON position.

Transmission should be in Neutral Range.

2. Release Park Brake and transmission should shift to Drive Range.

3. Set Park Brake and transmission should shift to Neutral.

Continue setting and releasing park brake a number of times to make sure the system is shifting at every action of the Park Brake.

4. Turn toggle switch of Auto Neutral control to OFF position and use the bottom push button to shift transmission to Reverse Range.

5. Turn the toggle switch of Auto Neutral to ON position and set the Park Brake.

The transmission should shift to Neutral Range.

6. Release the Park Brake and transmission should shift to Drive Range.

7. Use top push button and shift transmission to one of the Forward ranges other than Drive Range.

8. Set the Park Brake ... no shifting should occur.

9. With Park Brake in ON position, use Bottom push button and shift transmission to Drive Range.

At release of button in Drive Range the transmission should shift to Neutral Range ... because Park Brake has been set to the ON position and transmission is in Drive.

Turn the toggle switch of Auto Neutral to OFF position.

Test and Adjustments are complete.

### Shift Legend for MT643,644,647 MT-653 & HT740 Series

**1**  
First Forward Range

**2**  
Second Forward Range

**3**  
Third Forward Range

**D**  
Drive Range

**N**  
Neutral Range

**R**  
Reverse Range

### Shift Legend for MT654 & HT750 Series

**1**  
First Forward Range

**2**  
Second Forward Range

**3**  
Third Forward Range

**4**  
Fourth Forward Range

**D**  
Drive Range

**N**  
Neutral Range

**R**  
Reverse Range





# Bennett Controls



Tel: 734-416-8000  
Fax: 734-416-9113  
www.froudehofmann.com

45225 Polaris Ct.  
Plymouth, MI. 48170

## Installation Bulletin

# S-HS653-01

to Allison Automatic Models  
MT - 643, 644, 647 & 653 Series

Transmission Station - Side-Mount, 6 Range, Electric/Hydraulic/Electric

Pub: IHS65301 12-89

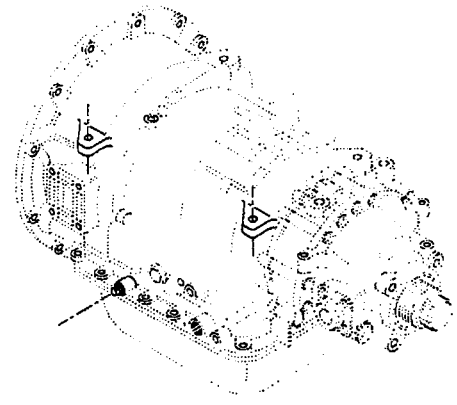
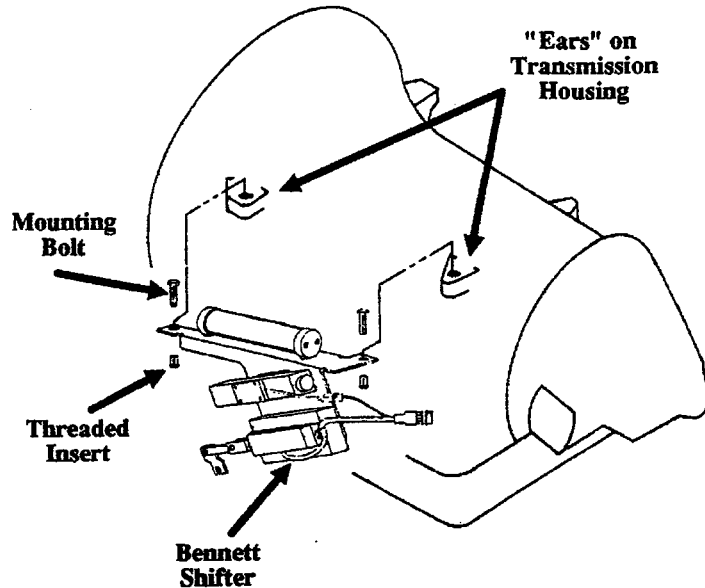

### GM Allison MT600 Series Transmission

The MT643/644/647 & MT653 models all use the same model of Bennett Shifter at the Transmission Station. Even though the MT653 has 5 forward ranges, only 4 of them are selectable through the Range Selector Shaft and has the exact same shift increments as the MT640 versions.

The MT654 and MT654(DR) have 5 forward selectable ranges and requires a 7-range Bennett Shifter at the Transmission Station. The shift increments are totally different from the models above and cannot be interchanged.

All Side-Mount MT600 shifters look very similar, so check the Serial Number Tag atop Shifter body for Model Number.

### Caution

Installation and adjustment of shifting unit does not require the engine to be running nor the transmission to be installed to engine or to vehicle. Do not attempt to install this shifting unit nor attempt any adjustments during operation of vehicle or under any unsafe conditions.

## Install Locking Inserts to Ears on Transmission Housing

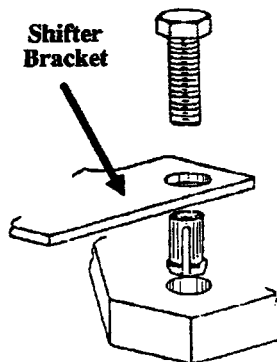

**Typical Assembly View**  
Inserts have to be installed into each "ear" of housing before installing the Bennett Shifter mounting bracket.

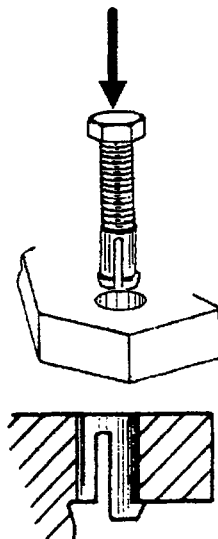

Insert Installed to "Ear"

Screw one of the Mounting Bolts into one of the Threaded Inserts about two turns. Locate Insert above front "ear" of transmission so that shorter leg of Insert will rest against housing side of ear as shown in Cross-Section view.

Apply a light coat of grease to outside of Insert and lightly tap the Insert into "ear" until legs of Insert snap into place at bottom edge. Tighten bolt a few turns to firmly seat the threads of insert to bolt.

Unscrew bolt from Insert and repeat for other "ear" of transmission housing. Remove Bolt from Insert.

Locate Mounting Bracket of Shifter to transmission "ears" as shown above. Make sure Shifter and Bracket are "in-line" with transmission housing and not cocked.

Apply a light coat of grease or oil to mounting bolts. Locate bolts through bracket into Inserts and securely tighten.

### Transmission Station

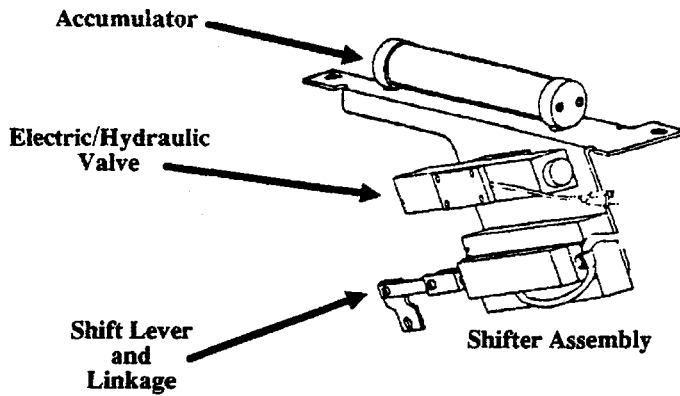

### Connect Hydraulic Return Hose to Sump Drain of Transmission

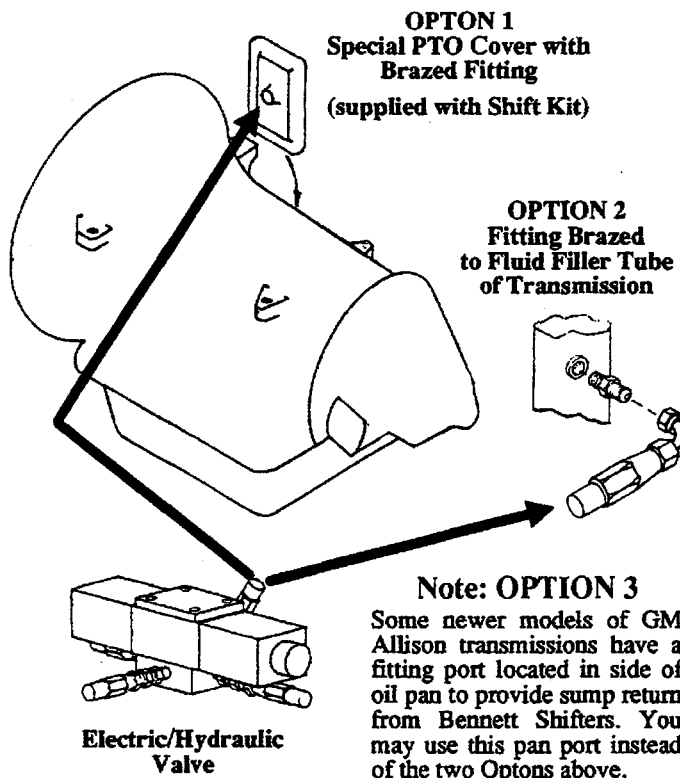

Choose one of the Options that best fits your application.

A special PTO cover is supplied with Kit for the Option 1 installation. The steel fitting attached to PTO Cover can be used as the connecting fitting in Option 2; however, the fitting required to "brazed" into filler tube is not supplied with Kit.

Loosen nut on "valve" end of hose. Attach other end of hose to steel fitting in Sump Port, but do not tighten.

Position hose in its most relaxed position without kinks or binds. Securely tighten nuts at both ends of hose as required to prevent leakage of transmission fluid.

### Connect Accumulator to Pressure Port

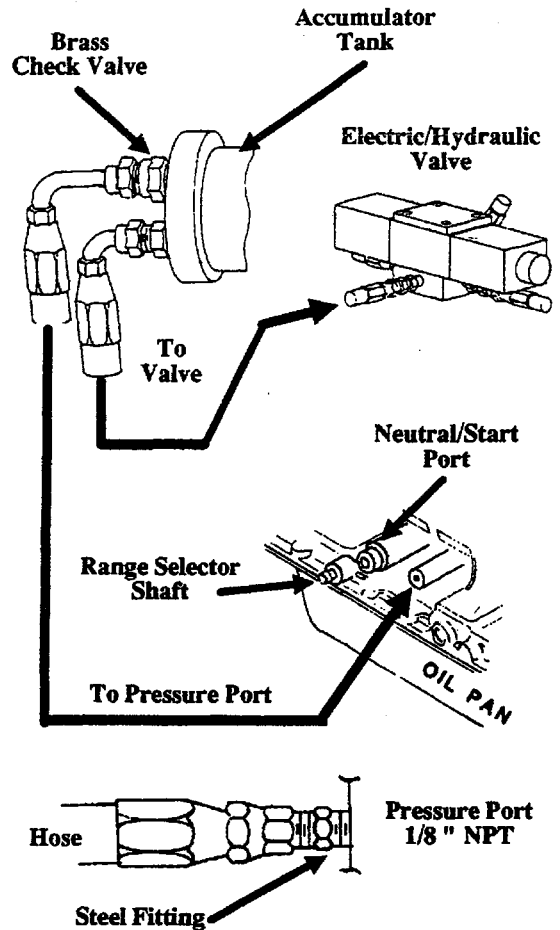

Remove plug at Pressure Port of transmission housing and install 1/8" steel fitting supplied with Shift Kit. Tighten securely as required to prevent leakage of transmission fluid.

Loosen nut on 90-degree hose fitting at Accumulator and route hose to Pressure Port location. This will be the hose that is connected to the brass check-valve in end of Accumulator as shown above.

Attach hose to steel fitting in Pressure Port, but do not tighten.

Position hose in its most relaxed position without kinks or binds. Securely tighten nuts at both ends of hose as required to prevent leakage of transmission fluid during operation of vehicle.



## Install Lever to Transmission Range Selector and Adjust

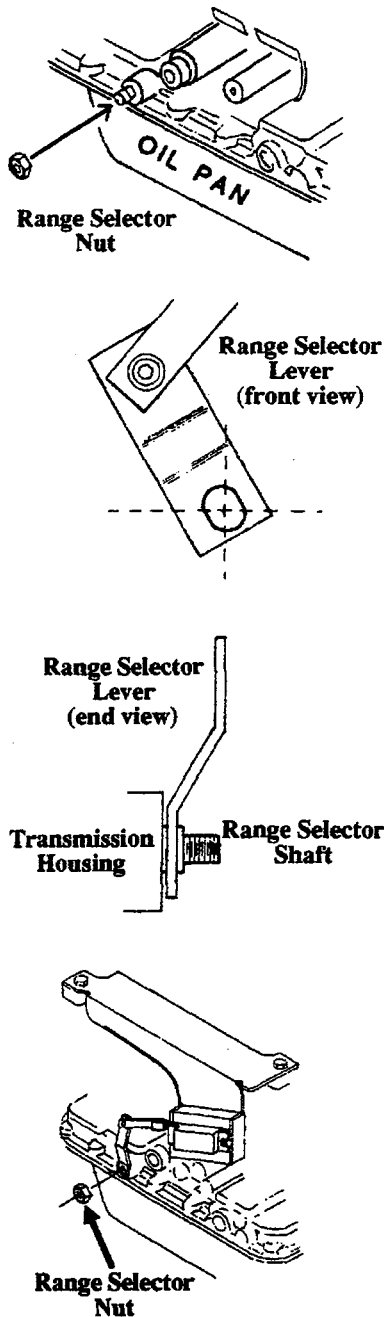

1. Remove Range Selector Nut from transmission selector shaft. **Do Not Lose.**
2. Loosen Jam-Nut located next to Clevis on Shaft of Shifter Assembly. Remove Shoulder-Bolt and Lock-Nut from Clevis. Swing linkage clear of Clevis. Set aside Round Spacer until re-assembly.
3. Install Lever to Range Selector Shaft of transmission as shown. Match the "flat" portion of hole over "flats" of shaft and firmly push lever into position. Re-install the Selector Nut and tighten. As nut begins to rest against Lever, the Lever should "snap" into place over the shaft. Securely tighten nut.
3. Locate the Range Selector Shaft on transmission to its Reverse range position. This will be the most counter-clockwise position of selector as shown below.
4. Firmly pull Shaft out of Shifter until it stops. This will be "dead center" Reverse position for the Shifter. Make sure the Shaft does not slip away from this "dead center" position during all adjustments.

Shifter and Range Lever are both resting in their respective Reverse Range positions. The task at hand is to adjust the Clevis so that Shoulder Bolt can be inserted back through the Clevis and Linkage without moving the Shaft or the Range Lever.

5. Holding Shaft firmly into place, rotate Clevis in direction required until hole in Clevis and corresponding hole in link "line-up" and Shoulder-Bolt can be pushed through front side of Clevis, through Link and out back side of Clevis with little if any force. Make sure the Range Selector nor the Shaft does not try to move while bolt is being pushed through the linkage. Remove Shoulder-Bolt when Clevis and Linkage are adjusted.
6. Locate Shoulder-Bolt through end of Ground-Strap and install bolt through back side of Clevis, through Round Spacer, Link, Flat Spring and out front side of Clevis. Re-install Lock-Nut and securely tighten.
7. Hold Clevis with a wrench and securely tighten Jam-Nut against Clevis. Make sure Clevis and linkage are not cocked or trying to bind.
8. Looking from top or bottom, the Link should be parallel with shaft and on the same center line as Clevis. If need be, loosen Mounting Bolts at Transmission Housing and push the slack in mounting holes as required to give best Linkage position and retighten mounting bolts. Check linkage again and make sure Link is in-line with Shaft and that Clevis is not cocked or crooked.
10. Rotate Lever through all range positions. Make sure Lever, Linkage and Ground Strap are moving freely and not trying to jam or bind. If need be, reposition Linkage until slack is about even for both Reverse and First Range positions.

Shifter is ready for final system test and adjustments.

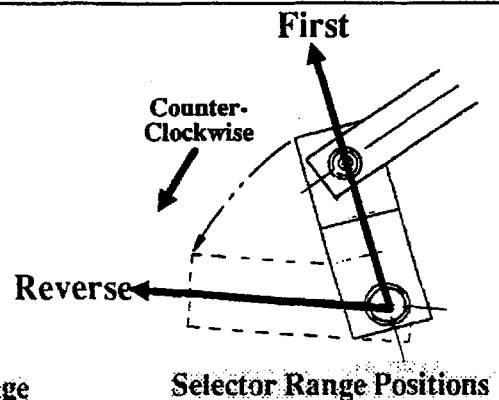
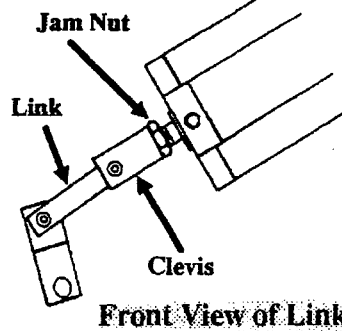
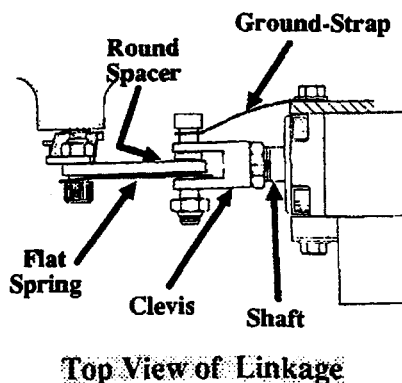



# Bennett Controls



Tel: 734-416-8000  
Fax: 734-416-9113  
www.froudehofmann.com

45225 Polaris Ct.  
Plymouth, MI. 48170

## Envelope Data

# 74xxx.xx

B-89 Harnessing Scheme  
16-Pin Round Molded Connectors

Description: All jacketing 105C rated, All injection molded connectors, Gold Plated pins.

Pub: E7400001.CHP 12-89

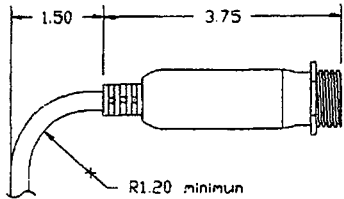

Side View

(AMP-16P)

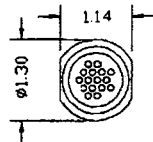

Front View

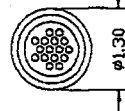

Front View

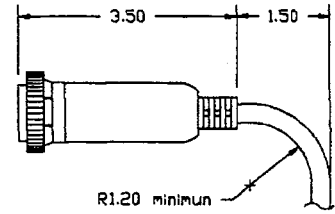

Side View

(AMP-16S)

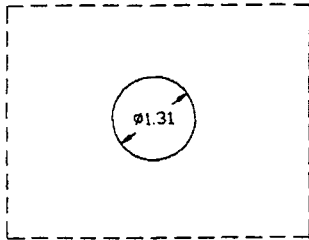

Clearance Holes  
(AMP-16P)

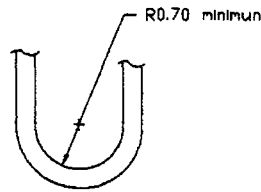

Cable bending radius

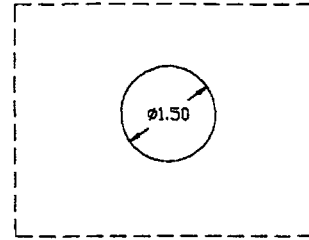

Clearance Holes  
(AMP-16S)

## Notes

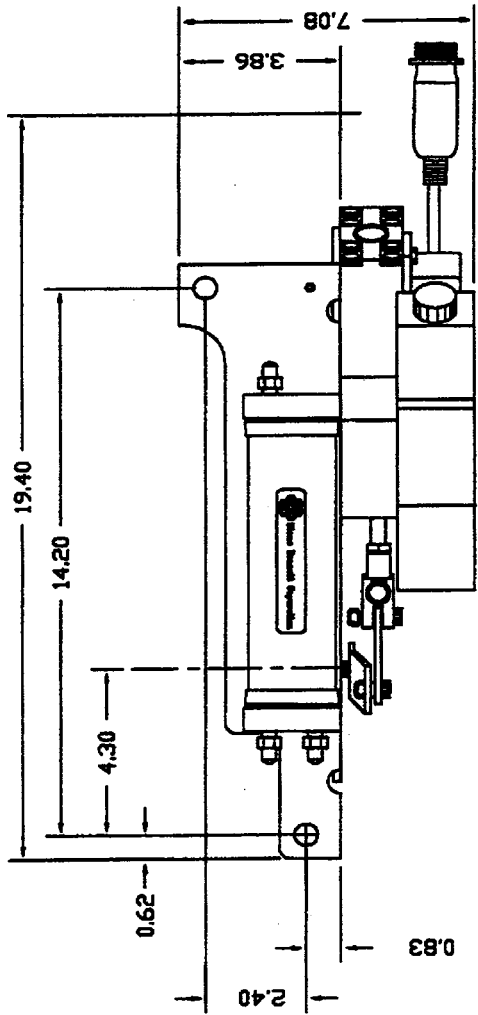

(Top View)

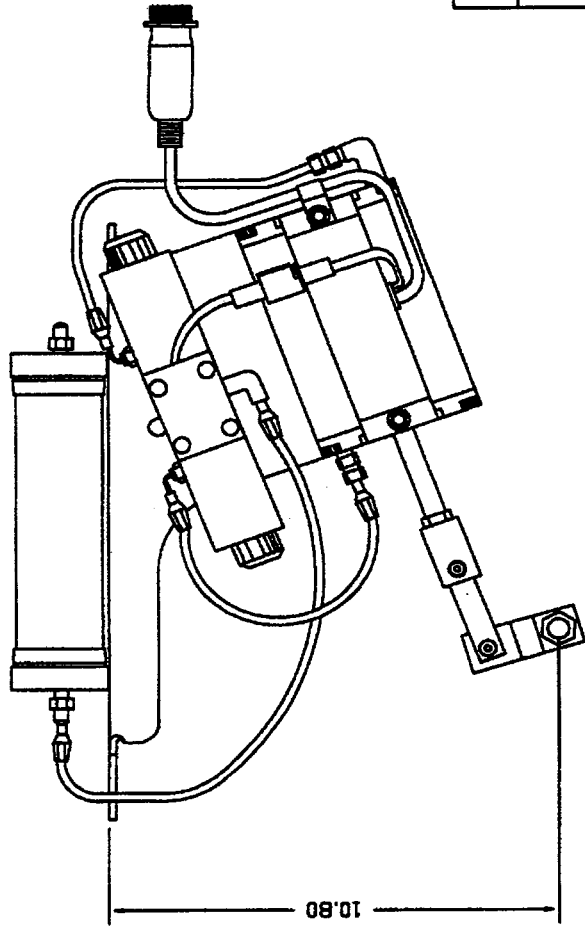

(Front View)

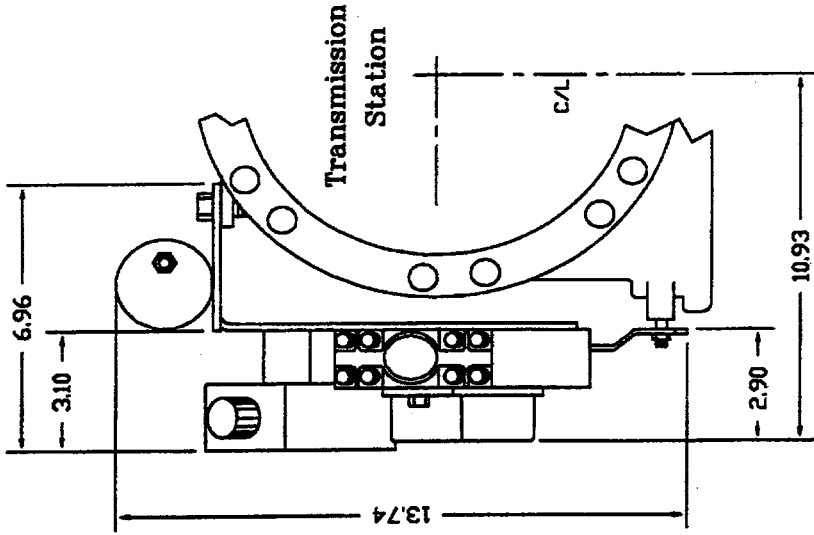

(End View)

Design :	BC group	Draw :	Tony	Check :	Dennis	Release Date :	01-23-90	Part # :	S-HS6xx-01	Next Assy :	xxxxxxx
Tel: 734-416-8000      www.froudehofmann.com											
Hydraulic Sidemount Envelope for 643/644/653      S-HS6xx-01 Env											
Part No :	08-22-01	Sheet :	1 of 1								
Rev :		Rev :									

Notes :  
1: -



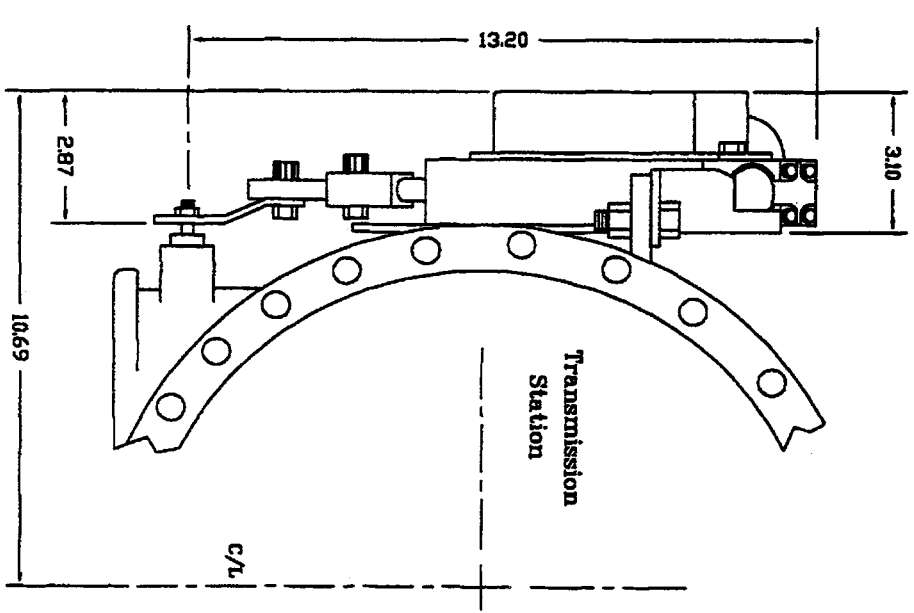
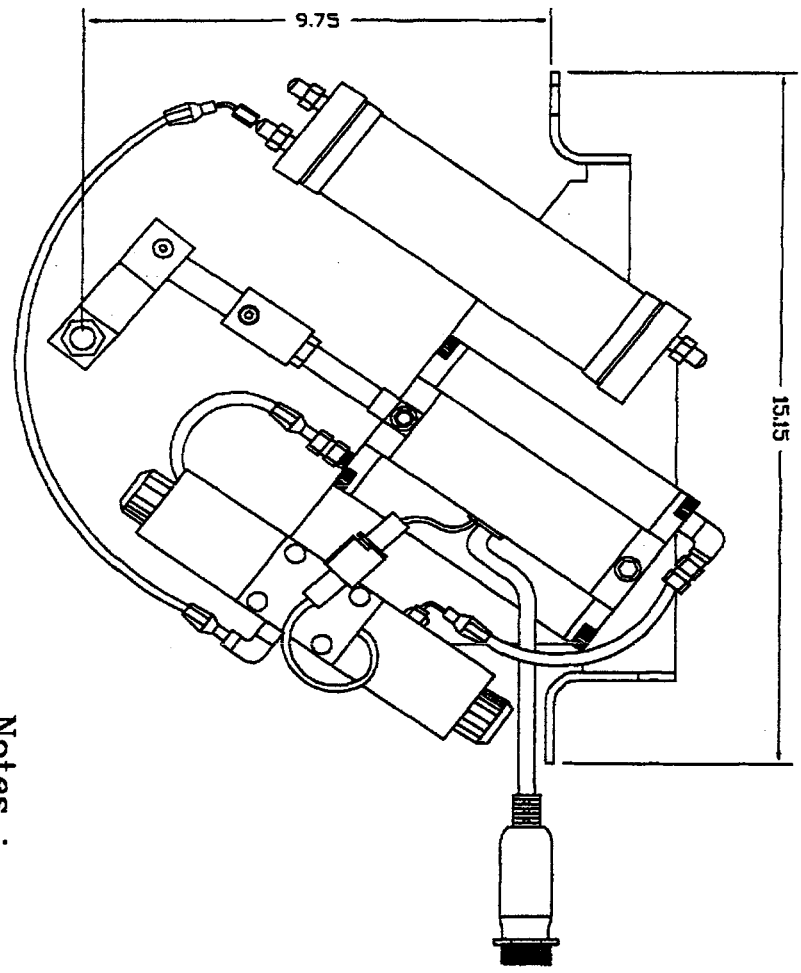
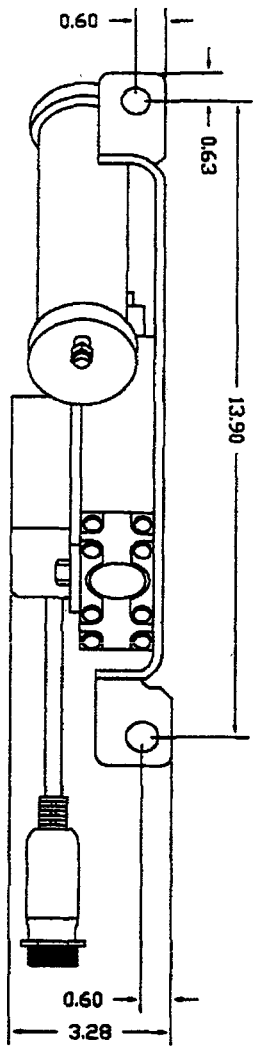

(Front View)

(Top View)

(End View)

Notes :

Design :	Draw :	Check :	Release Date :	Part # :	Next Assy :
HC group	Tony	Dennis	01-24-90	S-HS7xx-01	XXXXXXXX
			Sheet 1 of 1 Rev: -		

Tel: 734-416-8000  
 www.froudeheftmann.com  
 Hydraulic Sidemount Envelope for 740/750  
 S-HS7xx-01 Env

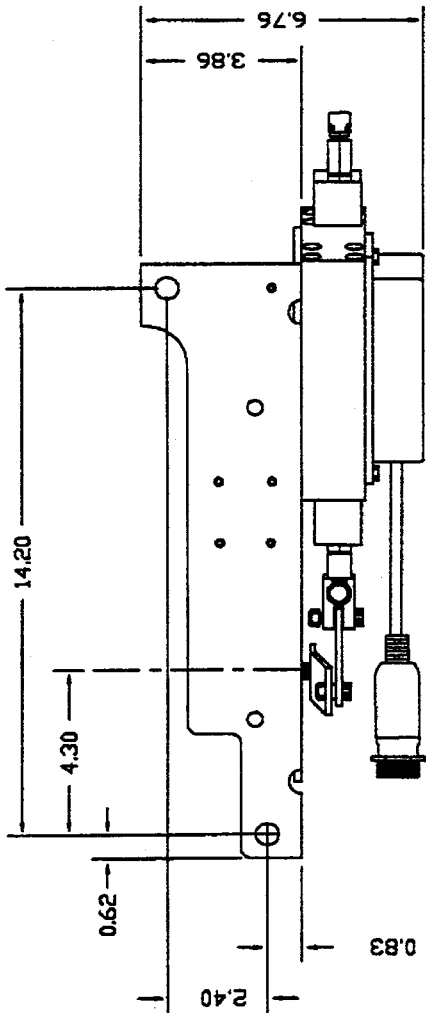

(Top View)

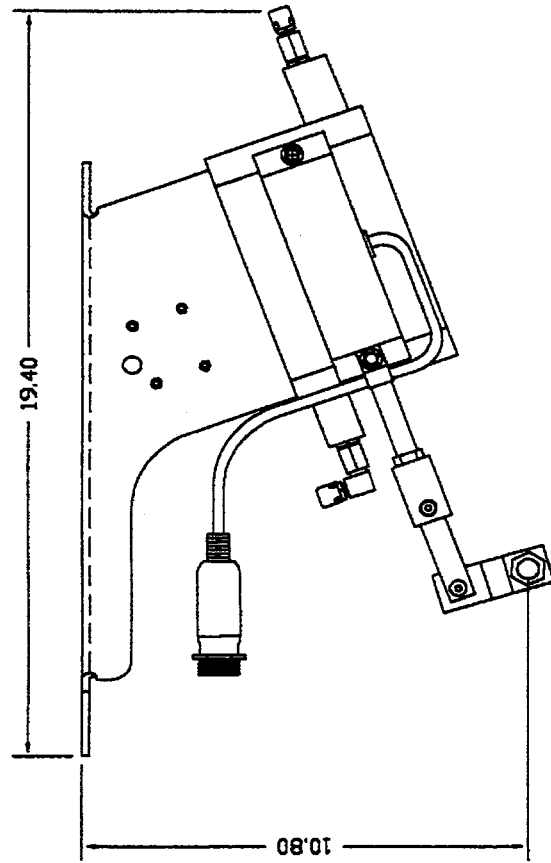

(Front View)

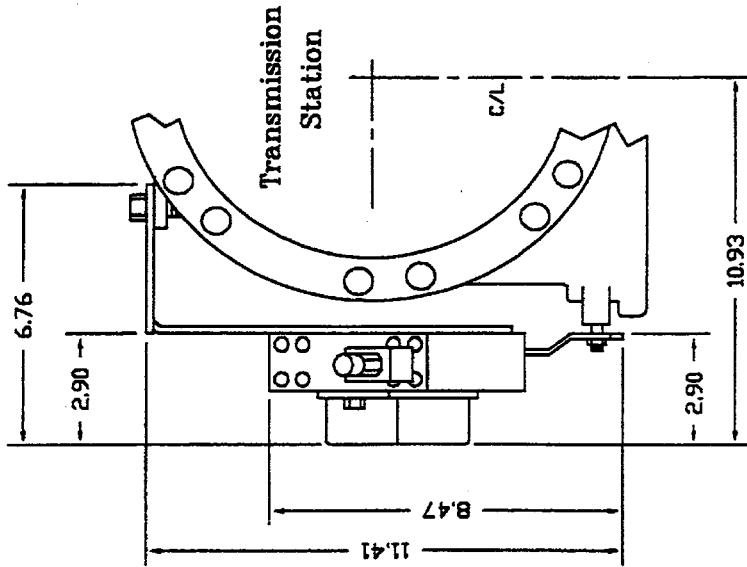

(End View)

Design : EC group	Draw : Tony	Check : Dennis	Release Date : 01-18-90	Part # : S-AS6xx-01	Next Assy : XXXXXXXX
 <b>Bennett Controls</b> www.froudehoffmann.com			Sheet 1 of 1 Rev. -		
Tel: 734-416-8000			Sidemount Envelope for 843/844/853		
			S-AS6xx-01 Env		

Notes :  
1: -

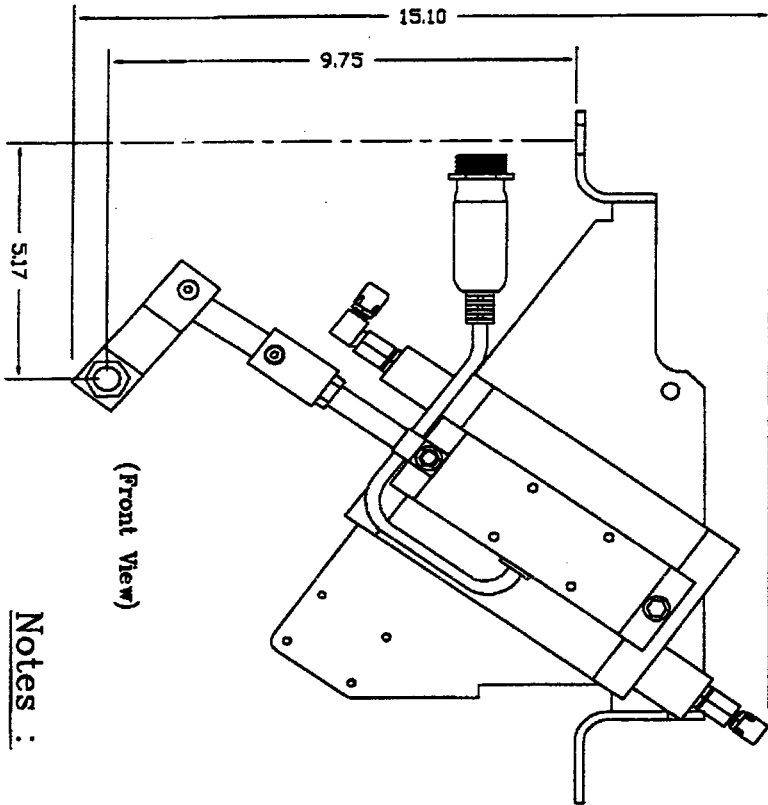
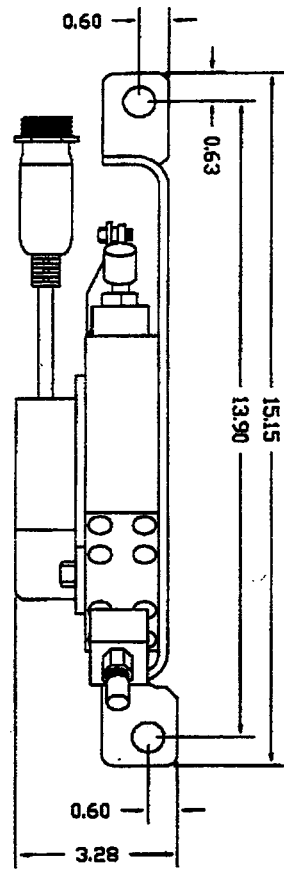

Notes :

1 :

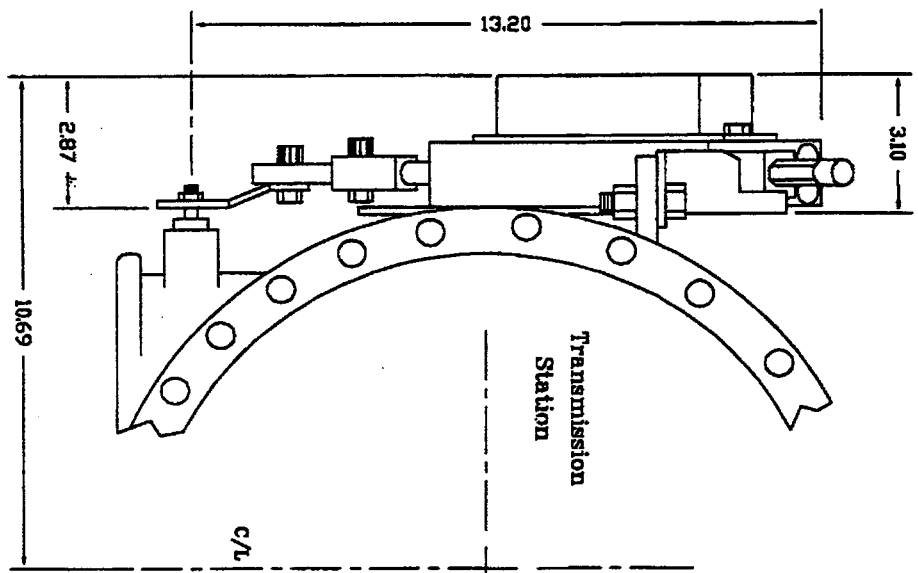

Design :	Draw :	Check :	Release Date :	Part # :	Next Assy :
HC Group	Tony	Dennis	01-18-90	S-AS7XX-01	xxxxxxx
			Sheet 1 of 1 Rev. -		
Tel: 734-416-8000 www.fraudehofmann.com			Date : 01-10-90		

Slidemount Envelope for 740/750

S-AS7XX-01 ENV

File No:  
sas7xx-e



Contact one of the AUTHORIZED Master Distributors below for GENUINE  
Stone Bennett Parts.

**Western Michigan Fleet Parts**  
18 East Washington Ave.  
Zeeland, MI 49464  
Phone 616-772-4606 (800-632-2010)  
Fax 616-772-0990

**T.H. Anderson Pump Company**  
103 Industrial Blvd.  
Kilgore, TX 75662  
Phone 903-984-5031 (800-594-7867)  
Fax 903-984-5035

**United Transmission Exchange**  
24147 East 6<sup>th</sup> Street  
San Bernardino, CA 92410  
Phone 909-384-8140 (800-527-1637)  
Fax 909-384-8145

**Reliable Transmission Service**  
6613 78<sup>th</sup> Street South  
Riverview, FL 33569  
Phone 813-677-8883 (800-344-0485)  
Fax 813-677-2800

**L & W Diesel Service**  
2600 West 43<sup>rd</sup> Street  
Odessa, TX 79760  
Phone 432-367-2747 (800-677-2747)  
Fax 432-367-0709

Bennett Controls are manufactured in the USA by

 **Froude Hofmann Inc.**

45225 Polaris Court  
Plymouth, MI. 48170  
U.S.A.  
[www.froudehofmann.com](http://www.froudehofmann.com)

Tel: 734-416-8000  
Fax: 734-416-9113

Part of the  FKI group of companies

# TRANSMISSION DETENT LOGIC

## What is a Bennett Shifter?

The Bennett Shifter is a bidirectional ratcheting device designed to assure precise, trouble-free shifting of automatic and powershift transmissions. The shifter can be controlled by electric or air signals, actuated by hydraulic or air pressure and can transmit the selected transmission range back to the operator via electric or air signals.

## The Transmission Detent Mechanism

All automatic or powershift transmissions have a built-in detent mechanism that is used to hold the transmission in a selected range. It is mandatory this positioning feature not be interfered with when moving the selector from range to range.

## Why Other Methods Fail

Most early transmission failures are caused by the detent being held out of position by constant pressure from stuck or corroded cables. The net effect is oil can be channeled to more than two clutches .. holding the transmission in two ranges at the same time.

## Why Use the Bennett Shifter?

The Bennett Shifter does nothing but go along for the ride, applying no forces to the detent until a shift is commanded by the operator. Each shift of the Bennett device is concluded by removing all forces from the range lever, allowing the detent and spring inside the transmission to seat the final detent position.

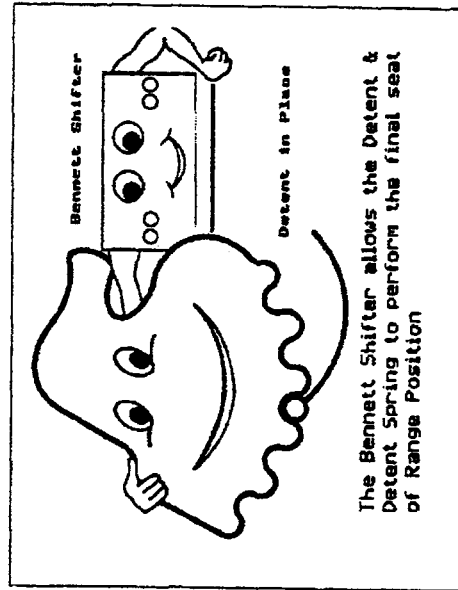
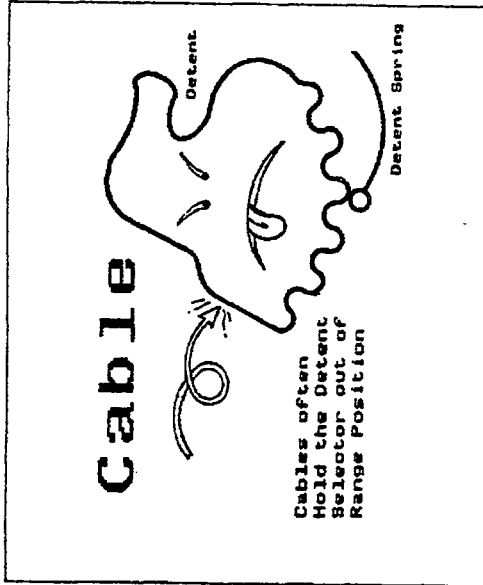

# SHIFTER OPERATING LOGIC

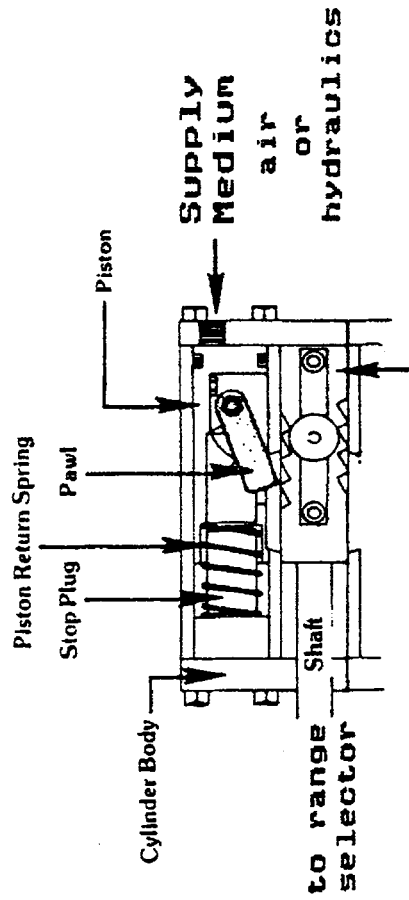

Figure 1 - Initial Position

1. The Power Medium (air or hydraulic oil) is applied to the Piston, forcing it against a Stop Plug and compressing the Piston Return Spring.
2. The Pawl is forced down by the Pawl spring and engages a Ratchet Slide, moving it exactly one shift increment. The Pawl and Piston are blocked by the Stop Plug at the end of shift to prevent overshifting. (See Figure 2).
3. The shift action is completed when the Power Medium is exhausted and the Piston Return Spring pushes the Piston back to its initial position (Figure 1).
4. The Pawl is retracted back into the Piston, thus releasing all forces on the range-selector shaft of the transmission. The detent and spring inside the transmission make the final seat of range position and hold the transmission in gear .... Not the Bennett Shifter.
5. Another shift either up or down may be made immediately.

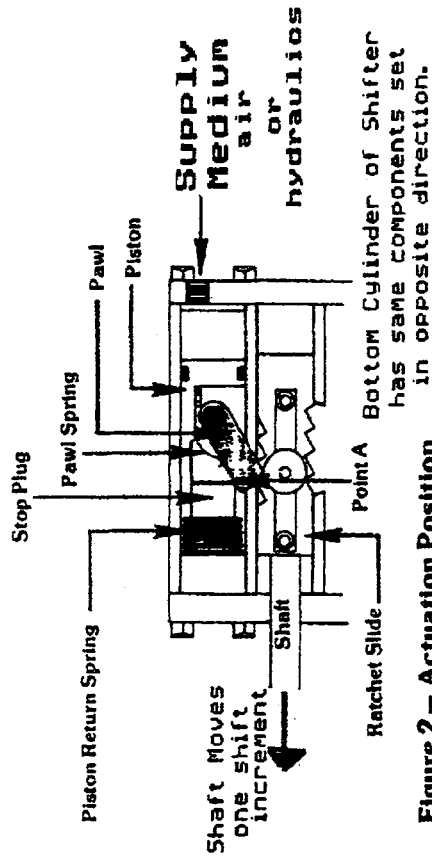
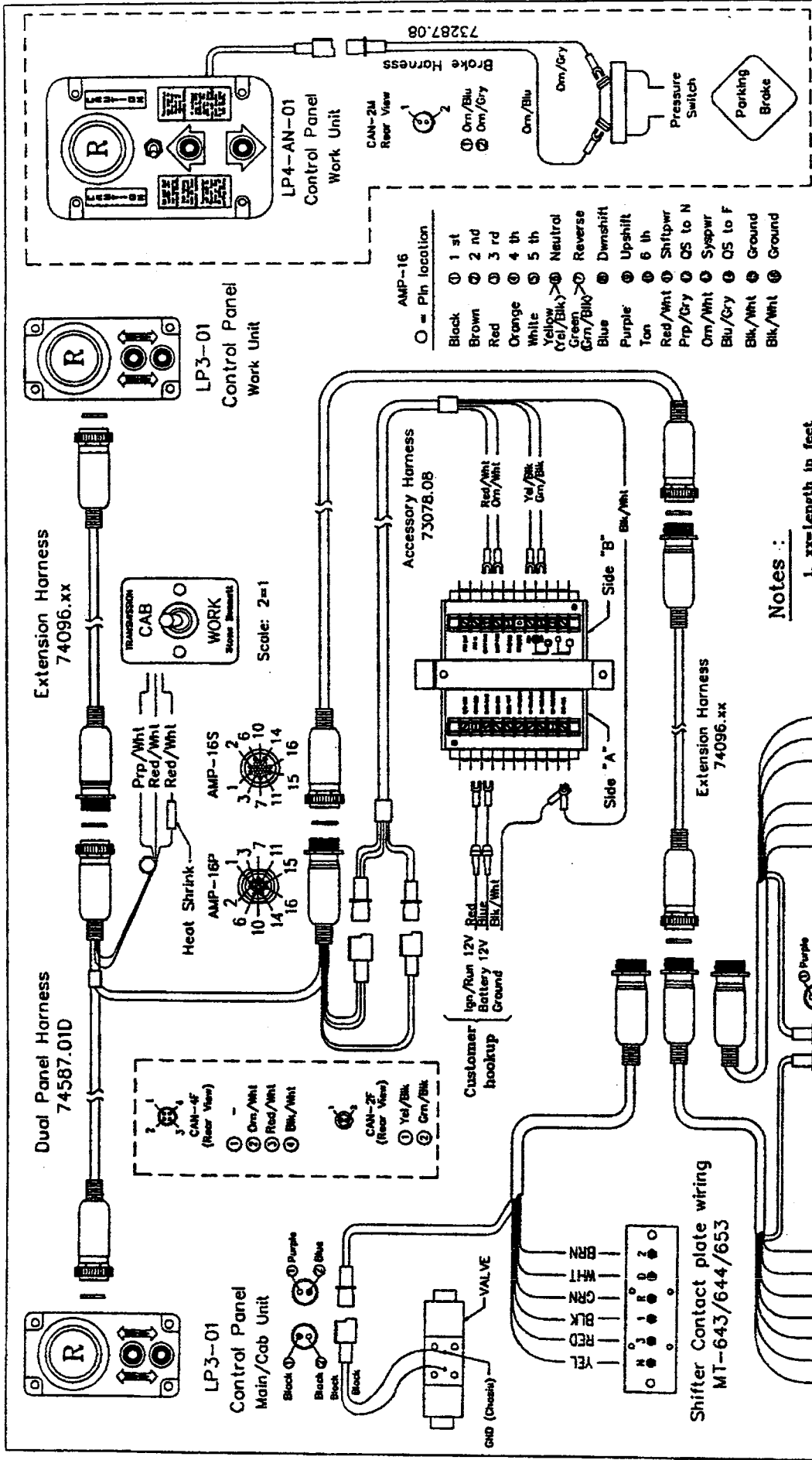

Figure 2 - Actuation Position



- AMP-16**  
 O = Pin location
- Black ① 1 st
  - Brown ② 2 nd
  - Red ③ 3 rd
  - Orange ④ 4 th
  - White ⑤ 5 th
  - Yellow ⑥ Neutral
  - Yel/Blk ⑦ Reverse
  - Green ⑧
  - Grn/Blk ⑨
  - Blue ⑩
  - Purple ⑪
  - Tan ⑫
  - Red/Wht ⑬
  - Ppr/Gry ⑭
  - Om/Wht ⑮
  - Blu/Gry ⑯
  - Blk/Wht ⑰
  - Blk/Wht ⑱

**Notes :**  
 1. xx=length in feet

Design :	BC group	Draw :	Tony	Check :	John	Release Date :	XX-XX-XX	Part # :	XXXXXXXX	Next Assy :	XXXXXXXX
<b>Bennett Controls</b>											
www.froudehoffmann.com											
Tel: 734-416-8000											
B-89 Functional Schematic						B-89 Schem					
File No :	B89-5	Sheet :	1 of 1	Rev. :	-	Date :	12-06-90				

### ***SHIFTING THE TRANSMISSION***

The top push-button of the shift control is for shifting into drive and the bottom button is for shifting into reverse. For all shifts from neutral toward first use the top button. For shifts toward reverse use the bottom button. A decal is attached to each control as a reference. To make a shift press the button down and hold it down until the "LED" indicates a range change. Release the button to complete the shift. The range indication on the LED is the range shifted to, not necessarily the range you intended. Continue shifting to the range required by pressing, hold and then release the button again. Pay attention as the range indicator changes from one range to another as you shift through the ranges to the required range.

### ***SHIFT-SHOCK ELIMINATOR***

Bennett Shift Systems feature "Shift Shock Eliminator". This feature prevents a shift from neutral to drive or to neutral to reverse unless the engine speed is near idle. Watch for a large dot or decimal to light when neutral is selected and the engine speed is below 850 RPM. Accelerating the engine will switch the dot off preventing the shift pads from shifting.

### ***DUAL CONTROLS***

Vehicles equipped with dual shift pads use a two position switch marked "WORK" and "CAB" to switch power from Cab (Street Side) to Work (Curb side). Note only one shift pad is active at any given time.

### ***AUTO-NEUTRAL***

The Auto Neutral feature found in the work station (on Dual Control Vehicles) or in the center of the truck (on single control vehicles) can become active when the transmission is in neutral (N) range. The toggle switch located on the shift pad (marked ON and OFF) must be switched to "ON" and the top push button used to select the drive (D) range. When the work brake or park brake is applied or set the shift control will sense the brake and shift to neutral (N). When the work brake or park brake is released the shift will be made to drive (D) range. This can only be accomplished if the engine speed is at or near idle. The Auto Neutral function will also operate when the reverse (R) position has been selected and the work brake is set. By releasing the work brake the unit will shift to drive.

### ***ENGINE STALLS IN RANGE***

The accumulator stores from 7 to 10 shifts to allow shift back to neutral (N) when engine stalls in range. If the engine stalls leave the ignition switched "on" and shift the transmission to neutral to restart the engine. The unit will not shift if the ignition switch is turned to "off" position.

### ***VEHICLE SHUT-DOWN***

Bennett Controls use the neutral (N) position signal for engine shut down. This eliminates engine from shut down when transmission is in any range other than neutral. **VEHICLE MUST BE IN NEUTRAL POSITION TO SHUT DOWN ENGINE.**



**NOTE:** In a dual Control-Station system, the LH / RH or CAB/WORK selector switch must be set to the LH or CAB position before testing.

\_\_\_1. **SHIFTING AND RANGE INDICATION.** Set Park-Brakes, start engine with engine at idle. Using the shift Selector, shift through all ranges paying attention to each range position and range indication. Indicators should be bright and not flickering. When equipped with dual controls, be sure to check the second control using the same procedures by switching the LH/RH or CAB/WORK switch.

\_\_\_2. **SHIFT SHOCK ELIMINATOR.** With engine idling, shift to Neutral, apply the foot brake, increase the engine speed to 900 or more rpm and attempt a shift from Neutral to Drive. If the transmission shifts, SHIFT-SHOCK needs attention! Adjust LINKAGE . Set cut out speed to 850 rpm.

\_\_\_3. **NEUTRAL OFF MODULE.** Allow engine to idle. Shift to Drive and switch ignition to "off" position. The engine should continue to operate. Shift to Neutral Range. The engine should immediately shut off without any further switches of ignition.

\_\_\_4. **ACCUMULATOR.** Idle engine for approximately two minutes. Shut down engine and switch ignition to "on" position. Use the range selector to shift between Neutral and Drive. There should be seven to ten shifts available. If there are less shifts available than those needed to shift from First to Neutral, the accumulator requires service.

\_\_\_5. **LINKAGE ADJUSTMENT AND WEAR.** Start engine, let idle a minute, charge Accumulator, then shut down engine. With an assistant watching the transmission selector shaft lever, Shift to Reverse and hold the Toggle or push-button engaged for 20 seconds after shift. Release the shift control. Shaft should not move. If shaft moves, the linkage is out of adjustment. To check linkage wear, hold the selector shaft and move the shifter shaft in and out of the shifter body without moving the selector shaft. **NO MORE THAN 25/ 1000's INCH WEAR IS PERMISSIBLE** .Replace link if out of tolerance.

\_\_\_6. **AUTO NEUTRAL. WARNING:** This test will shift the transmission into range. Make sure the **SERVICE BRAKE IS APPLIED** and remains **APPLIED** throughout the test.

**NOTE:** The CP-AN-02 Control will only transfer to the street side control when the transmission is in neutral. The green and red LED indicate which control is active. The newer model LP4-AN-01 uses a "ON" and "OFF" switch for transfer. When the switch is in the "ON" position it becomes the active control.

With engine running and transmission in Neutral, apply FOOT BRAKE and WORK BRAKE (Hand-TOGGLE). The Auto-Neutral DOES NOT shift. Release Hand Brake and notice the range selection and a shift to Drive Range. Apply Hand Brake again and notice the Control shifts to Neutral. Setting the Hand Brake again should shift the Transmission to Neutral.

INSPECTOR\_\_\_\_\_

DATE\_\_\_\_\_

**Feel free to copy this form and use it for your permanent records.**

## "SYSTEM WON'T SHIFT"

### CAUTION

Make sure park brakes are applied  
and engine is at "idle" speed.

The first step is to determine if the problem is mechanical or electrical.

### MECHANICAL TESTING

1. Start at the transmission station by disconnecting the master harness from the shifter harness. Hold the selector lever firmly and move it back and forth. There are several detent positions and each has a crisp snap. Should any positions not have a sharp detent, replace the detent spring (Refer to Allison service and parts manual). Shifter and linkage must move freely.

2. Position the lever toward the engine and down to the lowest position (Reverse) . Bump up one detent position to neutral.

3. Locate and disconnect the electrical connector (approximately two inches long and one half inch diameter). The end attached to the pilot valve has two contacts (a male pin and a female socket). This is referred to as upshift and downshift.

4. Use a jumper wire from battery power to supply power for testing. Touch the jumper wire to pin #8 (male pin). Shifter should move one range from Neutral to Drive.

5. Apply power to pin #9 (female socket). Shifter should move one range from Drive to Neutral.

6. Check the shifter linkage adjustment. Apply power to pin #9 (female-socket) and hold power to pin paying attention to linkage. Release power to the pin paying attention , once again, to the linkage. The linkage SHOULD NOT move. If the linkage moves then it is out of adjustment and you should move on to Step 7.

7. Linkage inspection. (a) Make sure that the socket head shoulder bolt is used in the linkage clevis, and torque; (b) Inspect the shifter linkage for wear (more than 25/1000 of an inch, or 1/8 inch wear causes erratic shifting). Replace the link if necessary. (c) Shift to reverse with the power jumper wire applied to pin #9. Hold the electrical power to pin #9 and observe the selector shaft level. Release the power to pin #9. The lever should not move. If the lever moves the linkage requires adjustment.

**LINKAGE ADJUSTMENT PROCEDURE:** Adjust the linkage by manually placing the selector shaft toward the engine and in the down (Reverse) range position. Remove the socket head shoulder bolt that connects the link and clevis. Slip the link out of the clevis. Pull the shifter shaft down or out. If the link does not line up with the clevis bores, loosen the jam nut that holds the clevis in place and rotate clevis until clevis bore and link bore line up. Tighten jam nut holding clevis in place. Test the position for adjustment. (Refer to step 5 above). Remember the linkage must not move as you replace the shoulder bolt that fastens the link and clevis.



**8. Accumulator functional test. (FOR HYDRAULIC POWERED SHIFTERS ONLY)**

(a) Switch the engine OFF and place the ignition switch to the "ON" or "RUN" position.

(b) Use the range selector and shift back and forth between Neutral (N) and Drive (D). Count the number of shifts that occur before the shifts stop. Notice the shifter display as it will be your only indication of the shifters movement. NOTE: The number of shifts needed will be shifts required from first range to Neutral. (MT-643/653 and HT-740 requires four shifts)(MT-654 and HT-750 requires five shifts) The accumulator should have enough reserve for as many as ten to twelve shifts if properly charged.

**ACCUMULATOR CHARGING PROCEDURE.** Stored hydraulic energy from the transmission pump provides shifting when an involuntary engine shut down occurs. **(THE CHARGE WILL HOLD FOR APPROXIMATELY ONE HOUR AFTER SHUT DOWN)**

(a). Loosen the 90 degree hose fitting attached to the accumulator . This is the fluid supply hose for the pilot valve. Allow the fluid to seep out as you apply a 90 PSI air charge.

(b). When the fluid stops seeping use a tire pressure gauge to test the accumulator air charge pressure. Pressure should be at 90 PSI. Charge if required.

(c). Re tighten the 90 degree hose fitting at the accumulator and check valve for air leaks

(d). Start and idle the engine for approximately three minutes to refill the accumulator.

(e). **(Cold Weather Pack Option Only)** Accumulator does not require charging as it is an on going process with each shift. With vehicle air system pressure at 90 PSI or more operating pressure each shift is super charged by air power.

NOTE: Air powered shifters use the stored air supply of the last air tank of the vehicle. An accumulator is not required for air powered shifters.

Once the above tests have been completed the transmission station has been completely checked out. The **Mechanical Testing** is complete. Reconnect the shifter harness to the master harness. If the problem still exists then move to the **Electrical Testing**.

**ELECTRICAL TESTING**

NOTE

Pins 1 through 7 are indication ground signals.

Pins 15 and 16 are system grounds.

**1. SHIFTER HARNESS (TRANSMISSION STATION)** Place the transmission in reverse and test pin #7 for a ground signal. Move the selector up one position and test pin #6 for a ground signal. Move selector up one more position to Drive (D) and test pin #5 for a ground signal. Continue this test through all ranges by moving the selector shaft one position at a time and check each pin for a proper ground signal. Fourth range - Pin #4, Third range - Pin #3, Second range - Pin #2 and First range - Pin #1.

**NOTE**

Power at pins #8 and #9 provide shift commands to the Pilot Valve. Power to pin #8 should supply a shift from Neutral (N) to Drive (D) . Power to pin #9 should supply a shift from Drive (D) to Neutral (N). Each time you supply power to a shift command pin (# 8 or #9) the shifter will move one range up or down.

2. Power to pins #8 and #9 provide shifts as described above indicates mechanics are OK.

**3. Harness testing : Shifter Harness**

(a) Disconnect the master harness from the control panel in the cab.

(b) Connect your test light to a battery power source.

(c) Apply the power lead to pin #8 of the master harness and observe a shift from Neutral (N) to Drive (D) range. The test light should light up. Touch pin #6 with test light. Test light should light up.

(d) Apply the power lead to pin #9. Look for a shift from Drive (D) to Neutral (N) as well as the test light to go on. Contact pin #7 and make sure test light is displayed.

(e) Jump power to pin #8 and release. Note the transmission shifted from Neutral (N) to Drive (D) then to the next lower range. For six range transmissions (MT-643/653 and HT-740) power applied to pin #3 should light the test light and shift transmission to third range.

(f) Energize pin #8 to shift again to shift to second range. Check pin #2 for light.

(g) Power pin #8 to shift to first range. Check pin #1 for light.

(h) Power pin #9 until you have the transmission back in Neutral (N).

Once the above has been successfully completed the master harness test is complete and the harness is good.

**4. Control Panel**

The range selection switch circuit provides upshifts or downshifts. One range in either direction may be accessed from the current range. The power supplied by the range selector is a pulse of 12V  $\pm$  20% and 3 to 7 Amps for a brief period. The energized solenoid (normally closed) opens and allows the power medium to exert force on the shifter piston surface. With the switch released the solenoid closes switching off the power medium and opens the exhaust port exhausting the power medium; thus completing a shift.

**5. Master Harness and Control Panel Harness "shift command test".**

(a) Using the test light connect the lead to a chassis ground. Switch the ignition switch to "on" position. Press the top push-button down and hold. Apply the light probe to pin #8. Light probe should light.

(b) Release the top push-button and press the bottom push-button. Apply light probe to pin #9. Light should be on. Releasing the push-button completes this portion of the test.

**6. Range selector push-button test.**

(a) Press the top push-button down and hold. Contact the test light to pin #8. Light should be on. Release top push-button

(b) Press the bottom push-button down and hold. Apply test probe to pin #9. Light should be on. Release bottom push-button. If light appears on both tests, shift commands are good.

**7. Master Harness / Control Panel Harness / Range Indication Circuits.**

- (a) Switch ignition to "ON" position. Connect test light probe to pin #1 of control panel harness. The LED Display on control panel should read "1".
- (b) Apply light probe to pin # 2 for a display of "2", pin # 3 for a display of "3", pin #4 for a display of "4", pin #5 for a display "D", pin #6 for a display of "N" and pin #7 for a display of "R". The range indication circuits are working properly if all digits display as described above.

**8. Accessory Box**

The standard box provides for input signals from the Neutral and Reverse ranges for the various output signal requirements. The Bennett shift system monitors the Neutral signal for features such as Neutral Off Module (NOM) and Shift Shock Eliminator. This same signal may be used for closing a circuit supplying power and overspeed protection for your PTO or another driven device. There are options available that would allow, for example, your back up lights and/or backup alarm to be energized when in reverse range.

**9. Accessory Box Power Harness (Wiring Kit) Side A**

Vehicle voltage is transmitted to the box when the master switch is in the "ON" position. This power supply wire requires a 10 AMPERE fuse or circuit breaker for protection. The RED wire (ignition wire) is connected to the terminal labeled IGN-RED on Side A of accessory box. This powers the shift system. The Battery power input (Batt-Blu) is connected to the terminal marked BATT-BLUE and the battery terminal of the ignition switch and a 10 AMPERE fuse or circuit breaker installed. Battery power is supplied at all times. This circuit only supplies power to the Neutral Off Module (NOM) feature and becomes functional when there is no ground signal at the Neu terminal and the ignition switch is in the "OFF" position. The third input is a ground signal. This ground signal is required to protect the accessory box from voltage spikes. The wire color is BLK/WH and is connected to a known chassis ground.

Optional signal wires may be attached to the two terminals labeled BU-RED/BLK. These terminals are provided for connecting a load device (**no more than 15 AMPERES**) and circuit for the reverse range of the transmission. Accessory box can be purchased that will allow you to have closed circuits in Neutral and Reverse.

**10. Accessory Box System Power Supply (Side B)**

Voltage of 5 to 7.5 volts is required at the terminal marked RPM-POS. This source is generally the alternator "R" terminal. However, the flywheel speed sensor can also be used. The wire color BLUE/RED, brings volts AC signal to measure the engine speed when the transmission is in the Neutral range and turn shift power off when the low set is exceeded (normally 850 RPM). With the ground signal present at the "Neu" terminal and the RPM's of the engine above the set point the shift power circuit opens to the shift control preventing the operator from shifting the transmission out of the neutral range.

**11. Reverse Range Indication Signal (Ground Signal)**

The reverse range signal relay can be ordered as an option to the accessory box. This relay is designed to close the circuit when the reverse position is selected. Maximum current capacity is 20 AMPERES. This option would be for rear camera or back up safety alarm.



## 12. PTO Engage and Over-speed Control

There are three models or modes of operation that may be used as options in the accessory box. The PTO control circuit is factory set and cannot be changed in the field.

PTO 1 = Engage and pack in Neutral range only

PTO 2 = Engage in Neutral and pack in range

PTO 3 = Engage and pack in range.

All modes respond to the engine "LOW SET RPM" setting for engagement and to engine "HIGH SET RPM" setting for over-speed protection. The "LOW" setting is the same as the Shift Shock Eliminator RPM. The "HIGH" set has an additional screw and LED installed.

### TESTING AND ADJUSTMENT

(a) The transmission must be in neutral with the engine at idle. Test the Accessory Box "SHIFT-PWR" terminal (Side B) for voltage of 9.6 to 14.5.

(b) If there is no voltage indicated, shut down engine and switch ignition to "ON" position. Read the "SHIFT-PWR" terminal for voltage 9.6 to 14.5 V.

NOTE "SHFT-PWR" terminal will not be powered if the red LED is not lighted.

(c) Start engine and allow to idle for adjustment of the "low-set" RPM. Shift Shock Eliminator set point (150 to 200 RPM above low engine idle speed). **DO NOT EXCEED 900 RPM**. Counter clockwise rotation of the adjusting screw (located on Side B) will lower the set point to maximum allowed engine speed. Clockwise rotation will increase the speed.

**NOTE: SEVERAL TURNS MAY BE REQUIRED TO ADJUST THE SET POINT**

(d) If the adjustment does not light the red LED, try using a jumper from the IGNITION (IGN) terminal over the accessory box to the SHIFT-PWR terminal. This test by passes the Shift Shock Eliminator circuit.

### **DO NOT OPERATE THE VEHICLE WITH THE JUMPER ATTACHED**

With the jumper in place try using the range selector to shift the system. With the shift power terminal powered the range selector should shift the system at least three times in both directions. If shifts do not occur the accessory box needs to be replaced.

Locate harness connection between the control panel and the master harness. Unlock the connector lock ring and pull the harness from the control panel connector. Locate pin #8 and pin #9. Install a jumper (with a circuit protection device) to a 12 volt power source. Apply the 12 volt lead to pin #8 and hold the connection for two seconds then release. This action should produce a shift from Neutral to Drive

# P / N 74044.01 SCHEMATIC

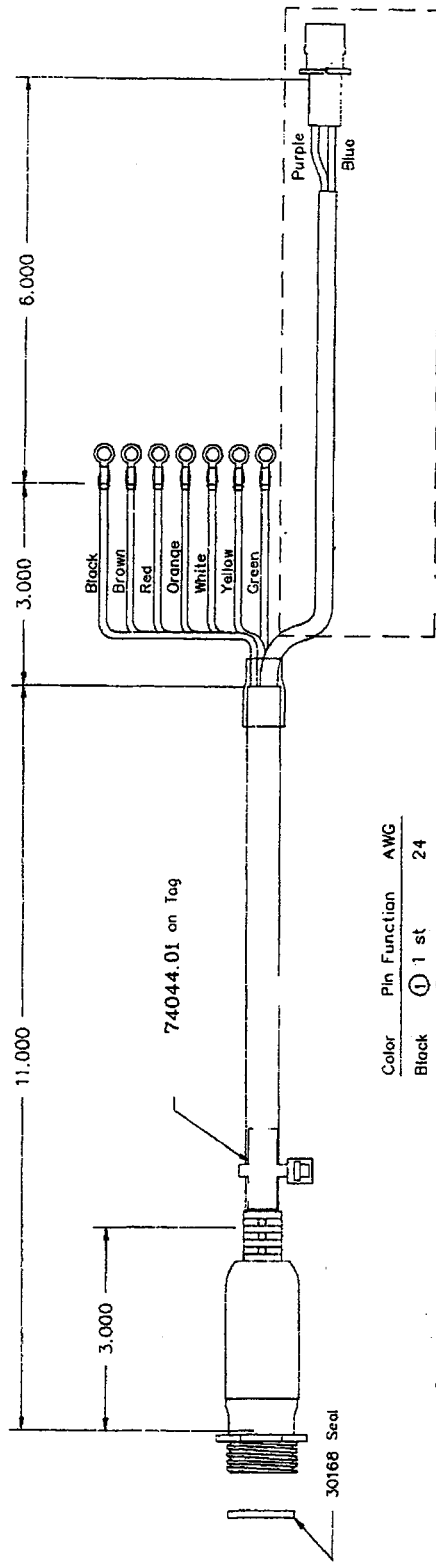

Color	Pin Function	AWG
Black	① 1 st	24
Brown	② 2 nd	24
Red	③ 3 rd	24
Orange	④ 4 th	24
White	⑤ 5 th	24
Yellow	⑥ Neutral	24
Green	⑦ Reverse	24
Blue	⑧ Shift N→D	18
Purple	⑨ Shift N→R	18
Tan	⑩ 6 th	18
Red/Whit	⑪ Shiftpw	18
Prp/Gry	⑫ QS to N	18
Orn/Whit	⑬ Syspw	18
Blu/Gry	⑭ QS to F	18
Blk/Whit	⑮ Ground	24
Blk/Whit	⑯ Ground	18

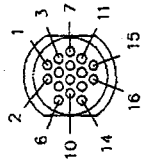

Rear View

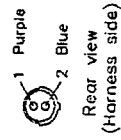

# P / N 74044.01N SCHEMATIC

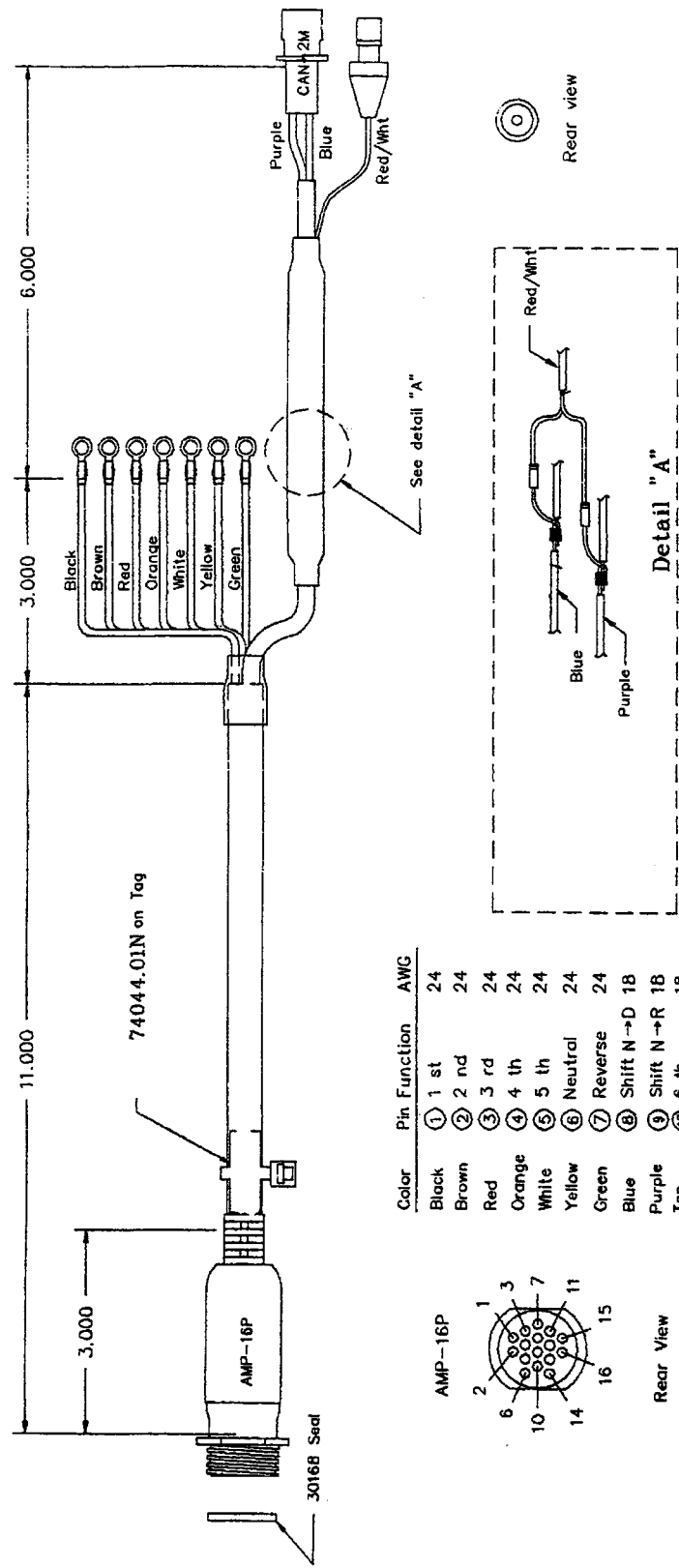

Color	Pin Function	AWG
Black	① 1 st	24
Brown	② 2 nd	24
Red	③ 3 rd	24
Orange	④ 4 th	24
White	⑤ 5 th	24
Yellow	⑥ Neutral	24
Green	⑦ Reverse	24
Blue	⑧ Shift N → D	18
Purple	⑨ Shift N → R	18
Tan	⑩ 6 th	18
Red/Wht	⑪ Shiftpw	18
Prp/Cry	⑫ QS to N	18
Orn/Wht	⑬ Syepwr	18
Blu/Gry	⑭ QS to F	18
Blk/Wht	⑮ Ground	24
Blk/Wht	⑯ Ground	18

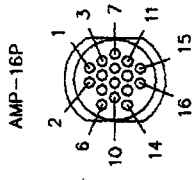

Rear View

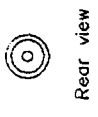

Rear view

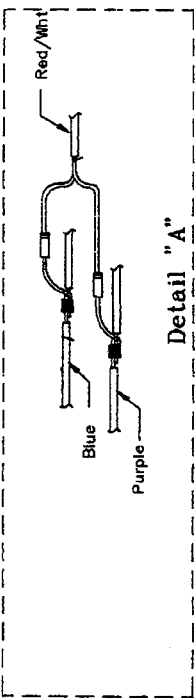

Detail "A"



# PART NUMBER 74046.XX - MASTER HARNESS

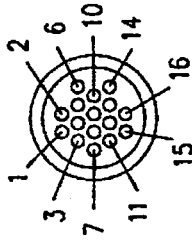
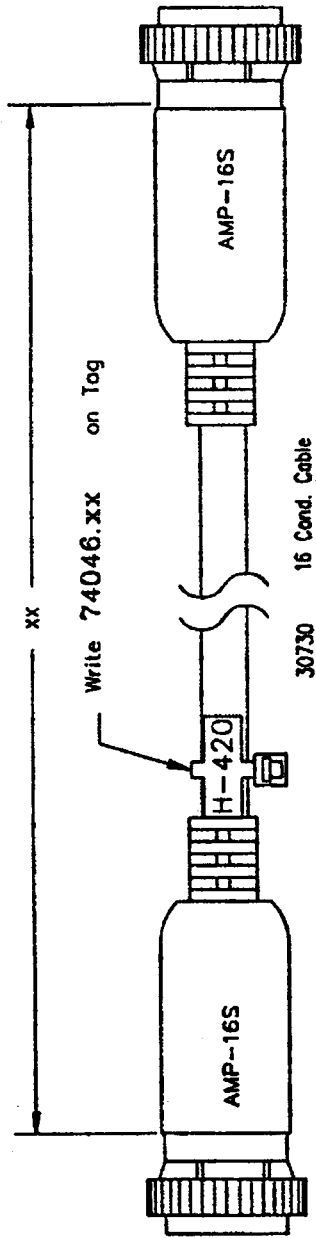

AMP-16S

Color	Pin	Function	AWG
Black	①	1 st	24
Brown	②	2 nd	24
Red	③	3 rd	24
Orange	④	4 th	24
White	⑤	Drive	24
Yellow	⑥	Neutral	24
Green	⑦	Reverse	24
Blue	⑧	Shift Fwd.	18
Purple	⑨	Shift Rev.	18
Tan	⑩	6 th	18
Red/Wht	⑪	Shift Pwr	18
Prp/Gry	⑫	QS to N	18
Orn/Wht	⑬	Sys Pwr	18
Blu/Gry	⑭	QS to F	18
Blk/Wht	⑮	Ground	24
Blk/Wht	⑯	Ground	18

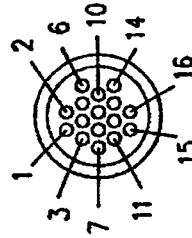

AMP-16S

Part #	XX--Length
74046.15	15'
74046.20	20'
74046.25	25'
74046.30	30'
74046.35	35'
74046.40	40'
74046.45	45'
74046.50	50'
74046.55	55'
74046.60	60'

# PART NUMBER 74096.XX - EXTENSION HARNESS

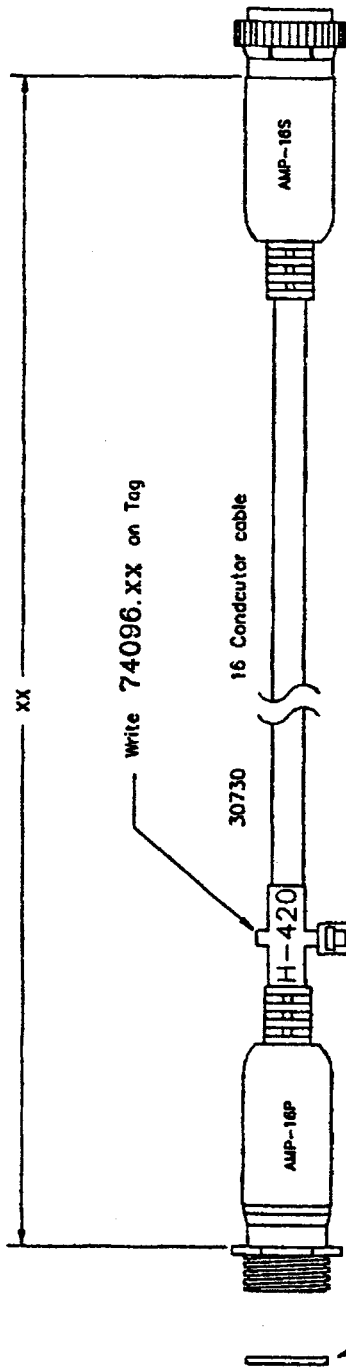

Color	Pin	Function	AWG
Black	①	1 st	24
Brown	②	2 nd	24
Red	③	3 rd	24
Orange	④	4 th	24
White	⑤	Drive	24
Yellow	⑥	Neutral	24
Green	⑦	Reverse	24
Blue	⑧	Shift N→D	18
Purple	⑨	Shift N→R	18
Tan	⑩	6 th	18
Red/Wht	⑪	Shift Pwr	18
Prp/Gry	⑫	QS to N	18
Orn/Wht	⑬	Lamp Pwr	18
Blu/Gry	⑭	QS to F	18
Blk/Wht	⑮	Ground	24
Blk/Wht	⑯	Ground	18

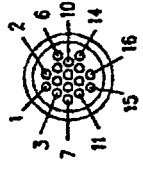

AMP-16S

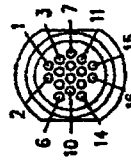

AMP-16P

Part #	XX-Length
74096.03	3'
74096.05	5'
74096.08	8'
74096.10	10'
74096.15	15'
74096.20	20'
74096.25	25'
74096.30	30'
74096.35	35'
74096.40	40'

# P/N 74587.01 SCHEMATIC

- 30168 1 Seal
- 
- AMP-16P  
Rear view  
(Harness side)
- 30223 1 Recept  
30170 16 Pin
- Black ① 1 st
  - Brown ② 2 nd
  - Red ③ 3 rd
  - Orange ④ 4 th
  - White ⑤ Drive
  - Yel/Blk >⑥ Neutral
  - Green >⑦ Reverse
  - Grn/Blk ⑧
  - Blue ⑨ Drnshift
  - Purple ⑩ Upshift
  - Tan ⑪ Tan
  - Red/Wht ⑫ Shftpwr
  - Prp/Gry ⑬ QS to N
  - Orn/Wnt ⑭ SysPwr
  - Blu/Gry ⑮ QS to F
  - Blk/Wht ⑯ Ground
  - Blk/Wht ⑰ Ground

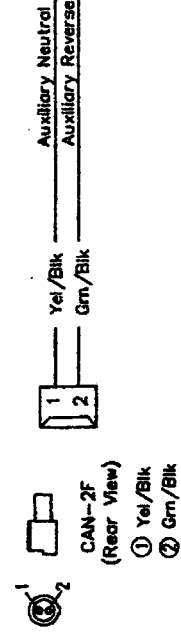
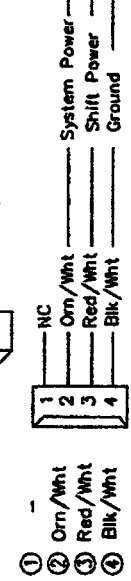
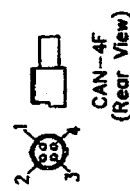
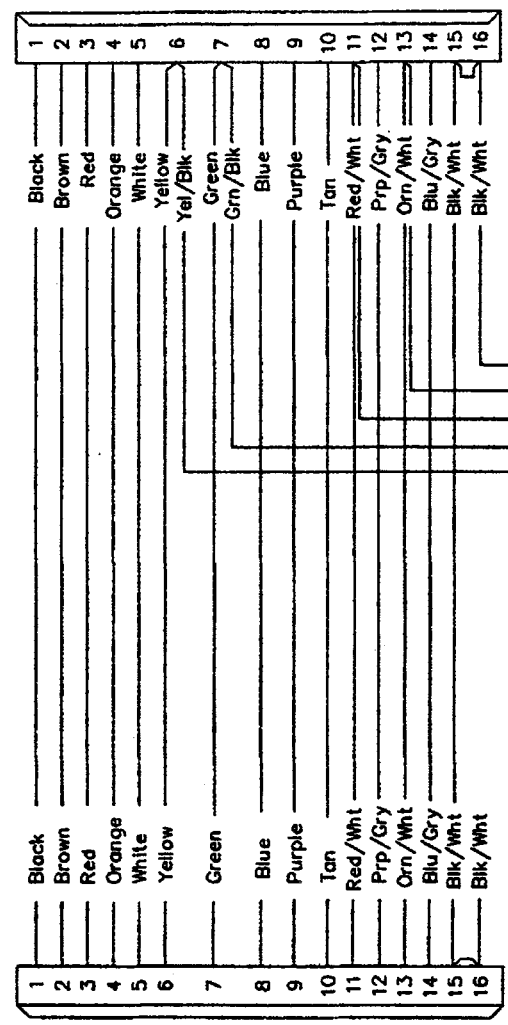
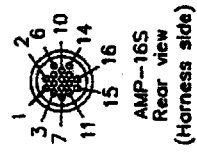
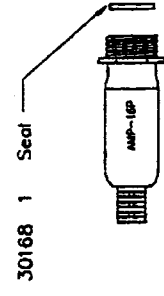

# P/N 74587.01D SCHEMATIC

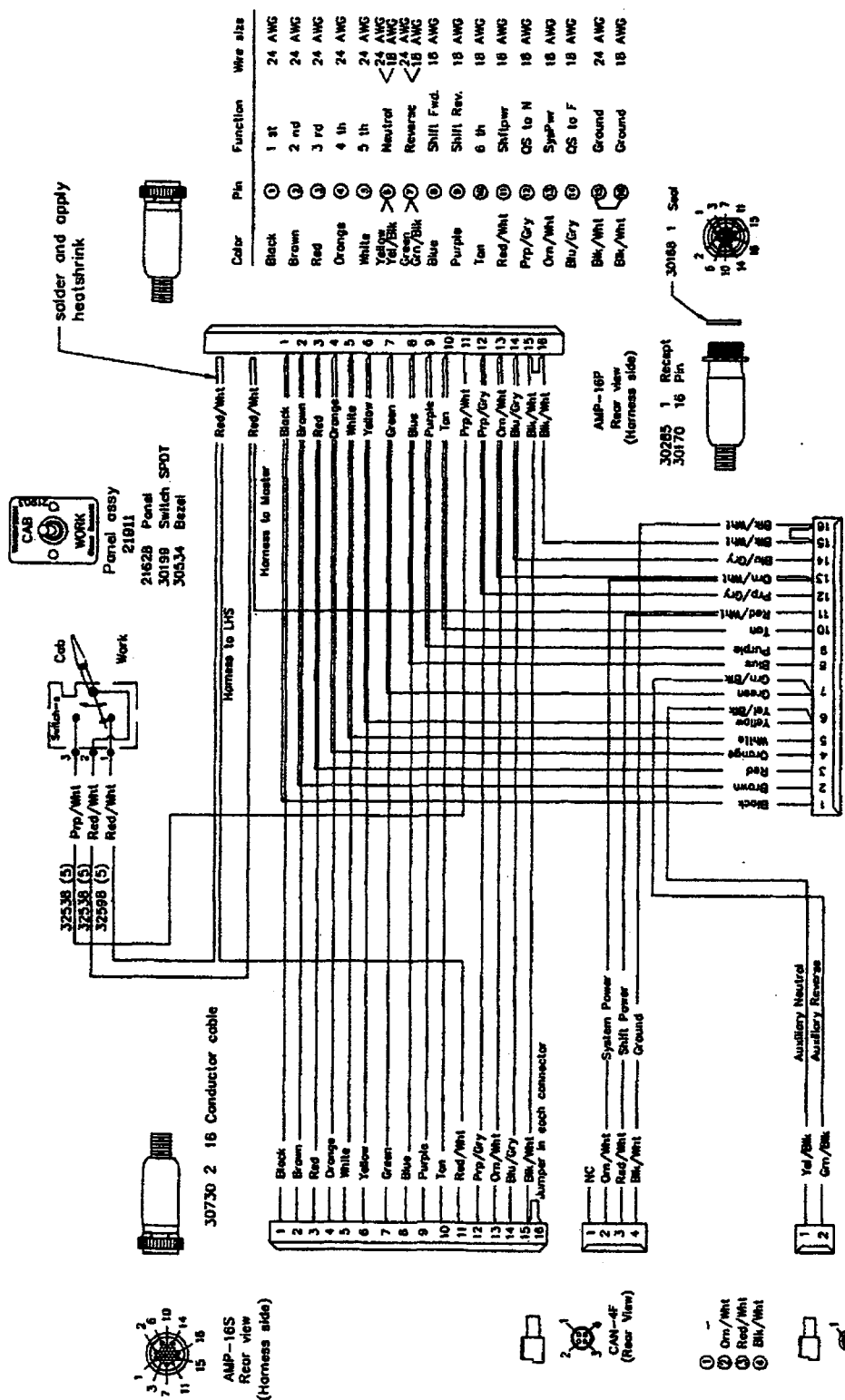

Color	Pin	Function	Wire size
Black	①	1 st	24 AWG
Brown	②	2 nd	24 AWG
Red	③	3 rd	24 AWG
Orange	④	4 th	24 AWG
White	⑤	5 th	24 AWG
Yellow	⑥	Neutral	24 AWG
Green	⑦	Reverse	24 AWG
Grn/Blk	⑧	Reverse	24 AWG
Blue	⑨	Shift Fwd.	18 AWG
Purple	⑩	Shift Rev.	18 AWG
Tan	⑪	6 th	18 AWG
Red/Wht	⑫	Shipwr	18 AWG
Prp/Gry	⑬	OS to N	18 AWG
Or/Wht	⑭	5pwr	18 AWG
Blu/Gry	⑮	OS to F	18 AWG
Blk/Wht	⑯	Ground	24 AWG
Blk/Wht	⑰	Ground	18 AWG



# Single System Component Identification

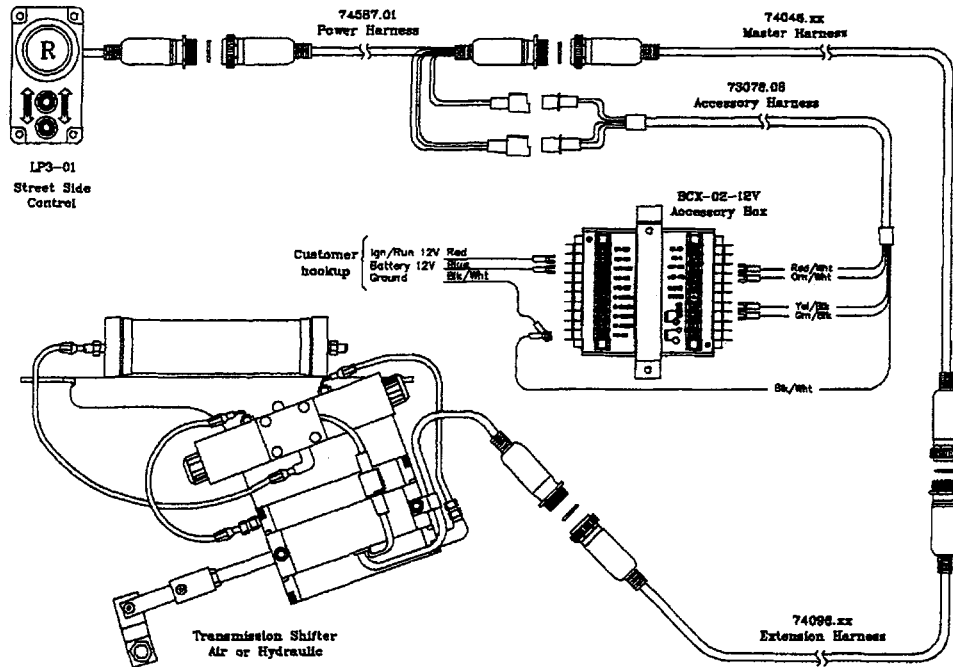

# Single Auto-Neutral System Component Identification

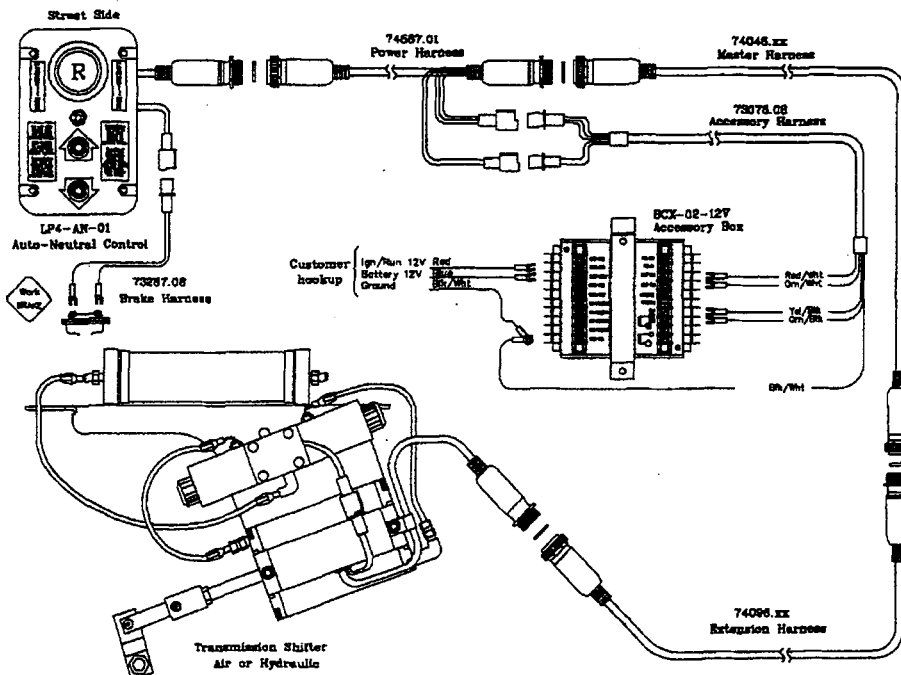

# Dual System Component Identification

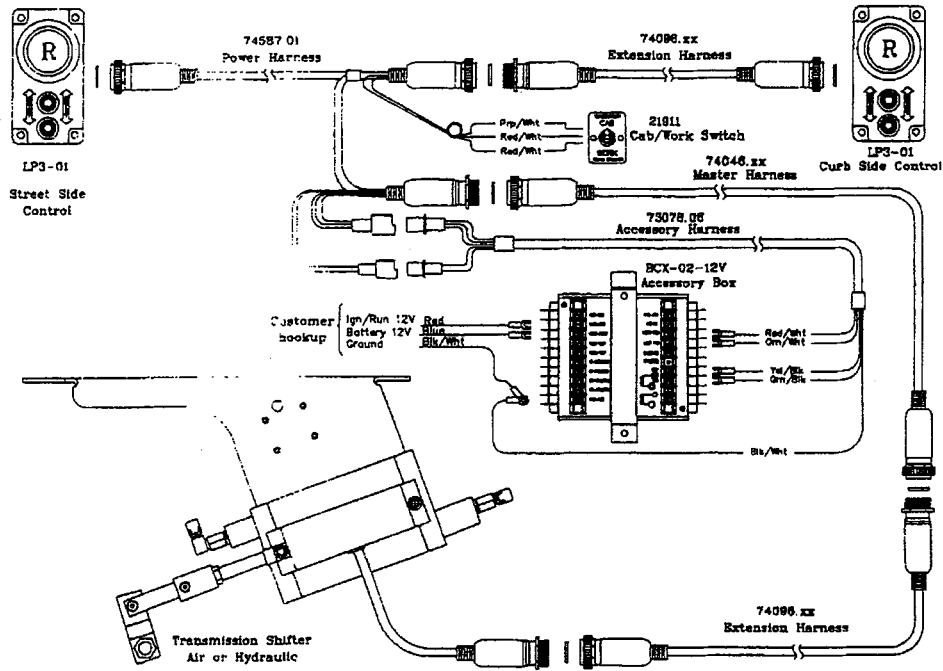

# Dual Auto-Neutral System Component Identification

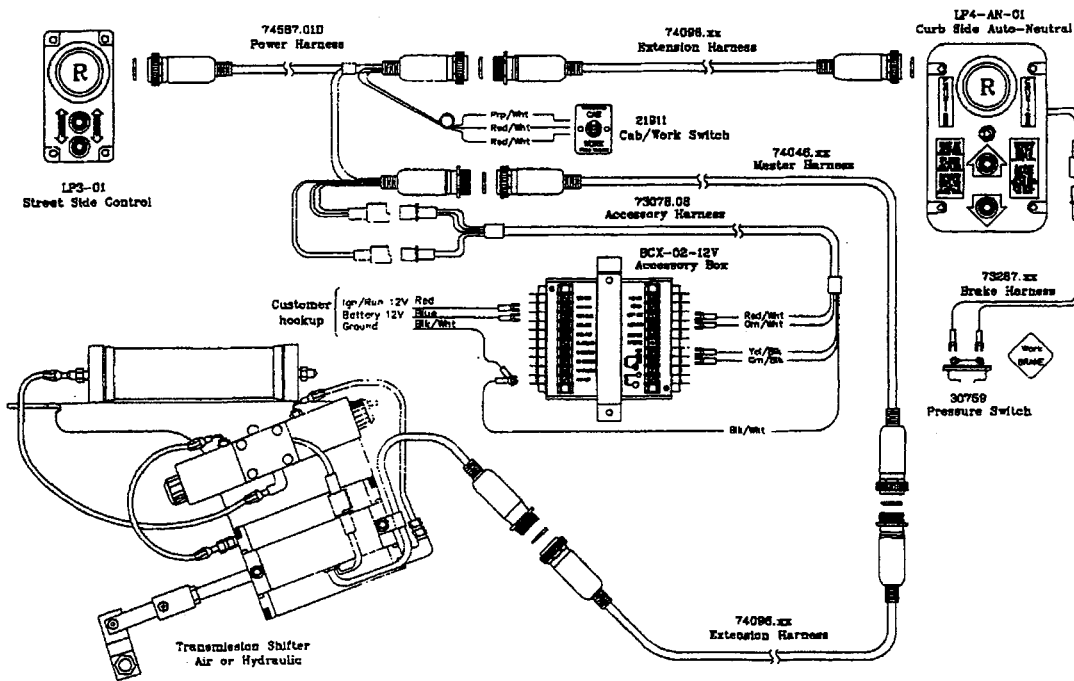

# Component Selection Chart

**CONTROL OPTIONS (Select As Required)**

PART NUMBER		DESCRIPTION		PART NUMBER		DESCRIPTION	
LP4-AN-01		Auto-Neutral, LED & Push Buttons		LP3-01		Control Panel, LED & Push Buttons	
<b>Accessories for LP4 Series Auto-Neutral Controls</b>				<b>Mounting Accessories for LP3 Series Control Panel</b>			
73287.xx 30759 ANR-01 74589.01DR LP4-AN-01R		Brake Sensor Harness (xx = Feet) Air-Brake Sensor Switch Auto-Neutral Range Restrictor Harness (Retrofit for CP-AN-02) Auto-Neutral Retrofit Kit (Includes Harness and Controller)		30760 30760F 30760I 30760M 30760Q 30760T		Mount LP3 to LP4 Hole Pattern Mount LP3 to Felsted Shift Tower Mount LP3 to Mack Shift Tower Mount LP3 to Morse Shift Tower Mount LP3 to Quadstat Shift Tower Mount LP3 to Teleflex Shift Tower	
<b>PANEL HARNESS OPTIONS (Select One)</b>				<b>TRANSMISSION STATION OPTIONS (Select One)</b>			
PART NUMBER		DESCRIPTION		PART NUMBER		DESCRIPTION	
74587.01 74587.01D		Single Control with Accessory Box Leads Dual Control with Accessory Box Leads		<b>Allison AT540 Series</b>			
<b>MASTER HARNESS (Select One)</b>				S-AS540-01 S-AS540-01R S-HS540-01 S-HS540-01N S-HS540-01R S-HS540-01NR		Side Mount (Air Powered) Side Mount (Air Powered) with Vibration Kit Side Mount (Hyd Powered) Side Mount (Hyd Powered) with Cold Kit Side Mount (Hyd Powered) with Vibration Kit Side Mount (Hyd Powered) with Cold and Vibration Kit	
PART NUMBER		DESCRIPTION		<b>Allison MT643, 644, 647, 653</b>			
74046.05 thru 74046.45		5 Foot Length (5 Foot Increments) 45 Foot Length		S-AS653-01 S-AS653-01R S-HS653-01 S-HS653-01N S-HS653-01R S-HS653-01NR		Side Mount (Air Powered) Side Mount (Air Powered) with Vibration Kit Side Mount (Hyd Powered) Side Mount (Hyd Powered) with Cold Kit Side Mount (Hyd Powered) with Vibration Kit Side Mount (Hyd Powered) with Cold and Vibration Kit	
<b>EXTENSION HARNESS (Select as Required)</b>				<b>Allison MT654</b>			
PART NUMBER		DESCRIPTION		S-AS654-01 S-AS654-01R S-HS654-01 S-HS654-01N S-HS654-01R S-HS654-01NR		Side Mount (Air Powered) Side Mount (Air Powered) with Vibration Kit Side Mount (Hyd Powered) Side Mount (Hyd Powered) with Cold Kit Side Mount (Hyd Powered) with Vibration Kit Side Mount (Hyd Powered) with Cold and Vibration Kit	
74096.02 thru 74096.18		2 Foot Length (2 Foot Increments) 18 Foot Length		<b>Allison HT740 Series</b>			
Note: All harnessing can be customized if need be to your particular requirements. Consult factory.							
<b>ACCESSORY BOX OPTIONS (Select One)</b>				<b>Allison HT750 Series</b>			
All boxes contain RPM Shift-Shock as standard.							
PART NUMBER		DESCRIPTION		S-AS740-01 S-AS740-01R S-HS740-01 S-HS740-01N S-HS740-01R S-HS740-01NR		Side Mount (Air Powered) Side Mount (Air Powered) with Vibration Kit Side Mount (Hyd Powered) Side Mount (Hyd Powered) with Cold Kit Side Mount (Hyd Powered) with Vibration Kit Side Mount (Hyd Powered) with Cold and Vibration Kit	
BCX-02-12V BCX-03-12V		No PTO nor Relay Features Reverse Relay		<b>Allison HT750 Series</b>			
<b>PTO Options</b>				S-AS750-01 S-AS750-01R S-HS750-01 S-HS750-01N S-HS750-01R S-HS750-01NR		Side Mount (Air Powered) Side Mount (Air Powered) with Vibration Kit Side Mount (Hyd Powered) Side Mount (Hyd Powered) with Cold Kit Side Mount (Hyd Powered) with Vibration Kit Side Mount (Hyd Powered) with Cold and Vibration Kit	
BCD-02-12V BCD-03-12V BCC-02-12V BCC-03-12V BCE-02-12V BCE-03-12V		Engage & Pack in Neutral Engage & Pack in Neutral, Reverse Relay Engage-Neutral, Pack-in Gear Engage-Neutral, Pack-in Gear, Reverse Relay Engage & Pack in Gear Engage & Pack in Gear, Reverse Relay		<b>Wiring Kit for Accessory Boxes (Select One)</b>			
74078.01 74078.02		Without PTO Options With PTO Options		<b>Accessory Box Harness to Panel Harness (Required)</b>			
73078.02 thru 73078.18		2 Foot Length (2 Foot Increments) 18 Foot Length					

# BCX SERIES ACCESSORY BOX\*

All Transmissions

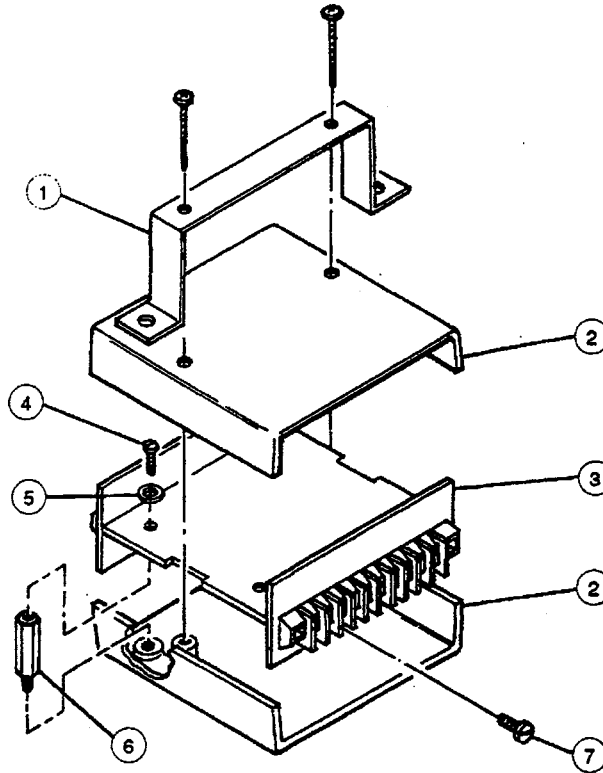

ITEM	QTY	PART #	DESCRIPTION	ITEM	QTY	PART #	DESCRIPTION
1	1	30450	Mounting Bracket; Accessory Box Hydraulic	4	2	H-378	Cap Screw; #4-40 x .375 slot head
2	1	30435G	Box Assembly; Accessory Box Hydraulic plastic with hardware	5	2	H-358	Washer; #4 lock internal star
3	**	Consult fact 2	PCB Assembly; Accessory Box Hydraulic without PTO	6	2	30443	Stand-Off; #4-40 x .750 .250 hex
				7	10	H-500	Cap Screw; #6-32 x .312 slot head

*BCX-02-12V	RPM SHIFT SHOCK NOM STANDARD WITHOUT PTO PROTECTION
BCX-03-12V	RPM SHIFT SHOCK NOM STANDARD WITH PTO PROTECTION
BCD-02-12V	RPM SHIFT SHOCK NOM STANDARD WITH PTO, ENGAGE & PACK IN NEUTRAL
BCD-03-12V	RPM SHIFT SHOCK NOM STANDARD WITH PTO, ENGAGE & PACK IN NEUTRAL WITH REVERSE
BCC-02-12V	RPM SHIFT SHOCK NOM STANDARD WITH PTO, ENGAGE-NEUTRAL, PACK IN GEAR
BCC-03-12V	RPM SHIFT SHOCK NOM STANDARD WITH PTO, ENGAGE-NEUTRAL, PACK IN GEAR W/REVERSE
BCE-02-12V	RPM SHIFT SHOCK NOM STANDARD WITH PTO, ENGAGE & PACK IN GEAR
BCE-03-12V	RPM SHIFT SHOCK NOM STANDARD WITH PTO, ENGAGE & PACK IN GEAR W/REVERSE



# LP3-01

## Control Panel, LED and Push Buttons

### All Transmissions

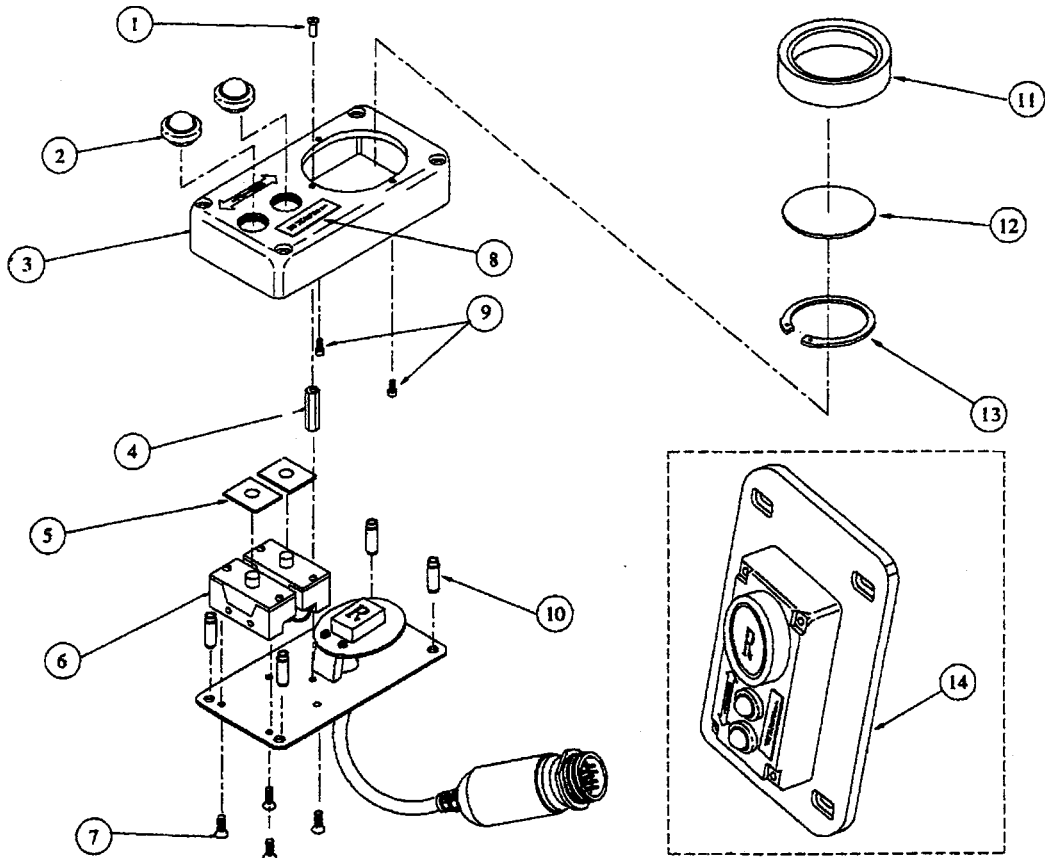

CONTROL PANEL PARTS LIST				BRACKET MOUNTING ACCESSORY			
ITEM	QTY	PART #	DESCRIPTION	ITEM	QTY	PART #	DESCRIPTION
1	1	30807	Nut; Self Cinching, 4-40 X .375	14A	1	30760	LP3 to LP4 Hole Pattern
2	2	31403	Push Button Cover	14B	1	30760F	LP3 to Felsted Shift Tower
3	1	21654H	Housing; LP3	14C	1	30760I	LP3 to Mack Shift Tower
4	1	30520	Standoff; 4-40 X 1	14D	1	30760M	LP3 to Morse Shift Tower
5	2	30725	Gasket; Push Button	14E	1	30760Q	LP3 to Quadstat Tower
6	2	31402	Switch; Push Button				
7	4	H-501	Screw; 6-32 X .250				
8	1	LP-DECAL	Decal				
9	2	H-424	Screw; LED-Housing Mount				
10	4	30758-2	Spacer; Mounting LP3				
11	1	21651-1	Housing; LED-Display				
12	1	30722-1	Lens; LED-Display				
13	1	30805	Retaining Ring; Lens				
14	1	Refer to Bracket Mounting Accessory Table	Mounting Accessory for LP3 (Choose One From 14A - 14E)				

# LP4-AN-01

## Auto-Neutral, Bright LED and Push Buttons

### All Transmissions

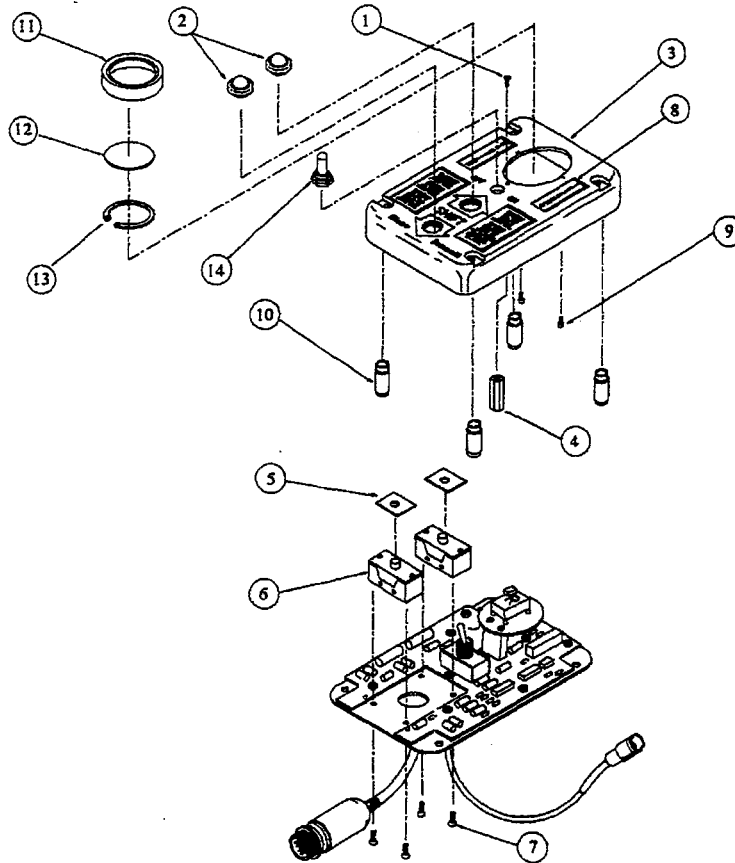

CONTROL PANEL PARTS LIST				BRACKET MOUNTING ACCESSORY			
ITEM	QTY	PART #	DESCRIPTION	ITEM	QTY	PART #	DESCRIPTION
1	1	30807	Nut: Self Cinching, 4-40 X .375	15A	1	30761F	LP4 to Felsted/Morse Shift Tower
2	2	31403	Push Button Cover	15B	1	30761I	LP4 to Mack Shift Tower
3	1	21650A	Housing: LP4	15C	1	30761Q	LP4 to Quadstat Tower
4	1	30520	Standoff: 4-40 X 1	15D	1	30761T	LP4 to Teleflex Shift Tower
5	2	30725	Gasket: Push Button				
6	2	31402	Switch: Push Button				
7	4	H-501	Screw: 6-32 X .250				
8	1	LP-DECAL	Decal				
9	2	H-424	Screw: LED-Housing Mount				
10	4	30758	Spacer: Mounting LP4				
11	1	21651-1	Housing: LED-Display				
12	1	30722-1	Lens: LED-Display				
13	1	30805	Retaining Ring: Lens				
14	1	H-312	Boot: Toggle Switch				
15	1	Refer to Bracket Mounting Accessory Table	Mounting Accessory for LP3 (Choose One From 15A - 15D) (NOT SHOWN)				

# S-HS654-01 / S-HS654-01R\*

Transmission Station: Side Mount, Hydraulic, 7-Range, RND4321  
GM Allison MT-654

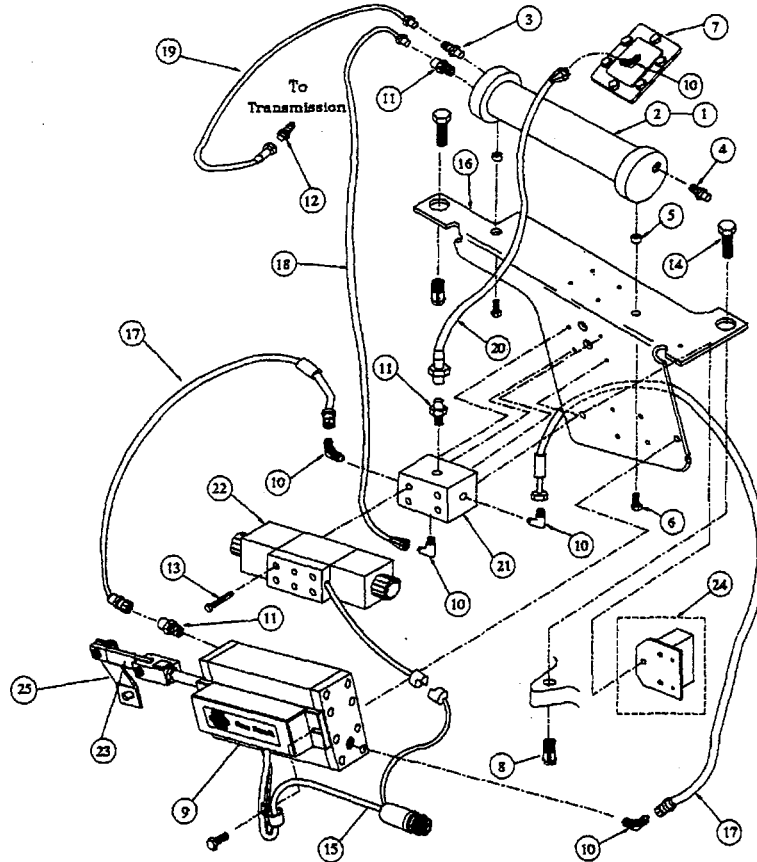

ITEM	QTY	PART #	DESCRIPTION	ITEM	QTY	PART #	DESCRIPTION
1	1	X30296-AV	Accumulator Assembly: Oil/Air 500 PSI, with All Fittings and Mounting Hardware (Items 2-6)	15	1	74044.01	Harness; Shifter
2	1	30296	Accumulator: Oil/Air 500 PSI	16	1	SB-7-26L	Mounting Bracket; Side Mount Hydraulic MT-654
3	1	21231	Check Valve; Hydraulic Accumulator	17	2	T-125.01	Hose Hydraulic; End Plates to Valve Subplate
4	1	30646	Filler; Air/Nitrogen Accumulator	18	1	T-125.04	Hose Hydraulic; Accumulator to Valve Subplate
5	2	C-27	Spacer; Accumulator Mounting	19	1	T-125.06	Hose Hydraulic; Accumulator to Transmission Pressure
6	2	H-174	Cap Screw; 5/16-18 x 1.000 Whizlock	20	1	T-127.05	Hose Hydraulic; Valve Subplate to PTO Cover
7	1	21053	Cover Assembly; PTO Hydraulic Pump Return	21	1	V-13B	Mounting Subplate; V-411 Pilot Valve
8	2	21261	Insert; Trans Ear 1/2-13	22	1	V-411E	Pilot Valve 12V; Hydraulic Shifter
9	1	S-SB7-67A	Shifter Assembly; Side Mount Hydraulic MT-654	23	1	RKIT-016	Linkage Kit
10	5	F-206	Fitting; 1/4 90 Degree Elbow MF	24	1	RKIT-012	Antivibration Kit (Optional)
11	2	F-211	Fitting; 1/4 to #4 JIC	25	1	SB-7-22G	(Includes Items 23 and 25) Clamp Lever
12	1	F-220	Fitting; 1/8 to #4 JIC to Transmission				
13	4	H-292	Cap Screw; #10-24 x 2.000 Skt Hd				
14	2	H-386	Cap Screw; 1/2-13 x 1.250 Hex Hd				

**NOTE**

\* Unit With Antivibration

**S-HS653-01 / S-HS653-01R\***

Transmission Station: Side Mount, Hydraulic, 6-Range, RND321

GM Allison MT-643/644/653

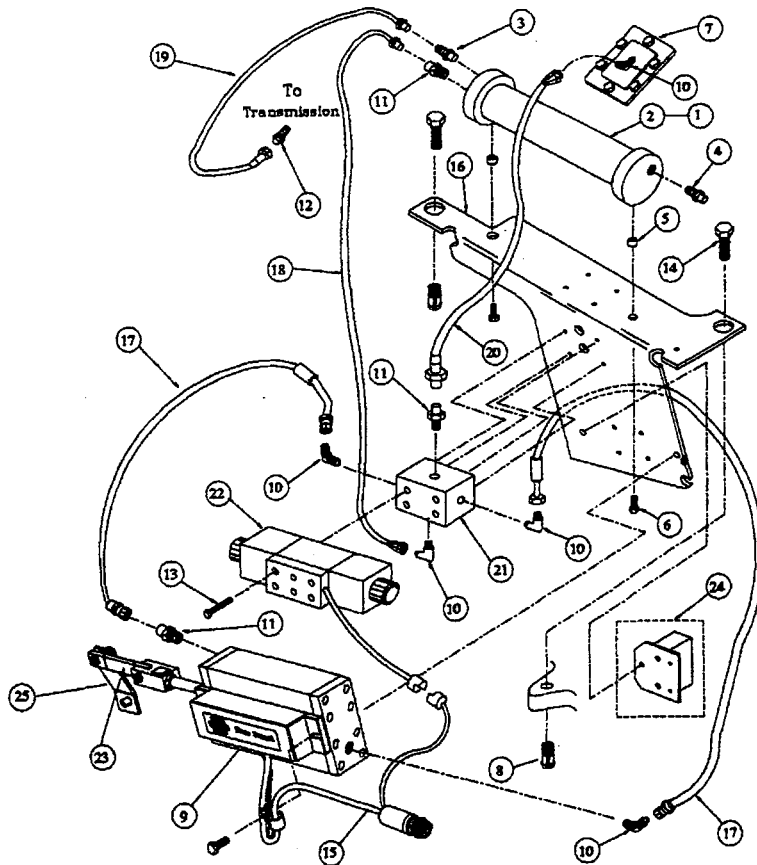

ITEM	QTY	PART #	DESCRIPTION	ITEM	QTY	PART #	DESCRIPTION
1	1	X30296-AV	Accumulator Assembly; Oil/Air 500 PSI, with All Fittings and Mounting Hardware (Items 2-6)	15	1	74044.01	Harness; Shifter
2	1	30296	Accumulator; Oil/Air 500 PSI	16	1	SB-6-26Y	Mounting Bracket; Side Mount Hydraulic MT-643/644/653
3	1	21231	Check Valve; Hydraulic Accumulator	17	2	T-125.01	Hose Hydraulic; End Plates to Valve Subplate
4	1	30646	Filler; Air/Nitrogen Accumulator	18	1	T-125.05	Hose Hydraulic; Accumulator to Valve Subplate
5	2	C-27	Spacer; Accumulator Mounting	19	1	T-125.06	Hose Hydraulic; Accumulator to Transmission Pressure
6	2	H-174	Cap Screw; 5/16-18 x 1.000 Whizlock	20	1	T-127.05	Hose Hydraulic; Valve Subplate to PTO Cover
7	1	21053	Cover Assembly; PTO Hydraulic Pump Return	21	1	V-13B	Mounting Subplate; V-411 Pilot Valve
8	2	21261	Insert; Trans Ear 1/2-13	22	1	V-411E	Pilot Valve; 12V Hydraulic Shifter
9	1	S-SB6-61A	Shifter Assembly; Side Mount Hydraulic MT-643/644/653	23	1	RKIT-016	Linkage Kit
10	5	F-206	Fitting; 1/4 90 Degree Elbow MF	24	1	RKIT-014	Antivibration Kit (Optional) (Includes Items 23 and 25)
11	2	F-211	Fitting; 1/4 to #4 JIC	25	1	SB-6-22F	Clamp Lever
12	1	F-220	Fitting; 1/8 to #4 JIC to Transmission				
13	4	H-292	Cap Screw; #10-24 x 2.000 Skt Hd				
14	2	H-386	Cap Screw; 1/2-13 x 1.250 Hex Hd				

## NOTE

\* Unit With Antivibration

# S-HS740-01 / S-HS740-01R\*

Transmission Station: Side Mount, Hydraulic, Electric Solenoids, 6-Range, RND321  
GM Allison HT-740

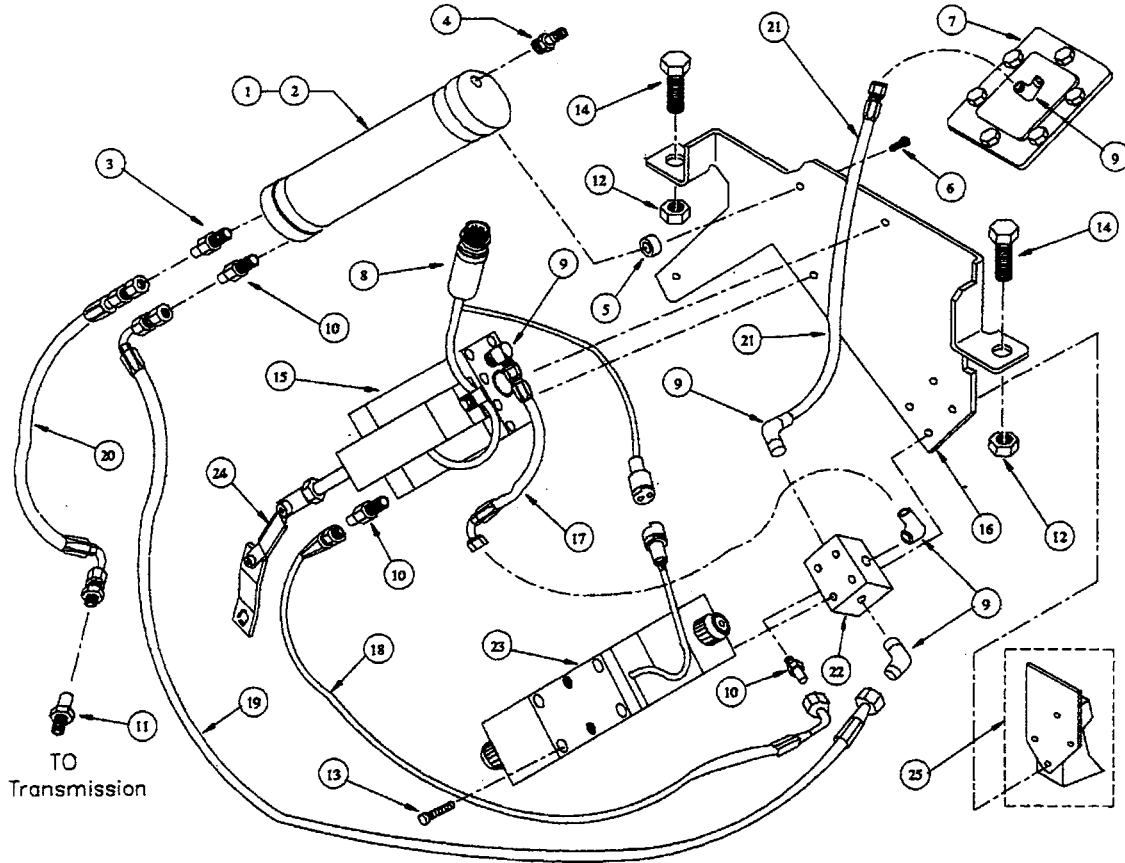

ITEM	QTY	PART #	DESCRIPTION	ITEM	QTY	PART #	DESCRIPTION
1	1	X30296-AV	Accumulator Assembly; Oil/Air 500 PSI, with All Fittings and Mounting Hardware (Items 2-6)	15	1	S-SB7-78A	Shifter Assembly; Side Mount Hydraulic HT-740
2	1	30296	Accumulator; Oil/Air 500 PSI	16	1	21 256	Mounting Bracket; Side Mount Hydraulic HT-740
3	1	21231	Check Valve; Hydraulic Accumulator	17	1	T-125.03	Hose Hydraulic; Top End Plate to Valve Subplate
4	1	30646	Filler; Air/Nitrogen Accumulator	18	1	T-127.10	Hose Hydraulic; Lower End Plate to Valve Subplate
5	2	C-27	Spacer; Accumulator Mounting	19	1	T-125.05	Hose Hydraulic; Accumulator to Valve Subplate
6	2	H-174	Cap Screw; 5/16-13 x 1.000 Whizlock	20	1	T-125.06	Hose Hydraulic; Accumulator to Transmission Pressure
7	1	21053	Cover Assembly; PTO Hydraulic Pump Return	21	1	T-127.03	Hose Hydraulic; Valve Subplate to PTO Cover
8	1	74044.01	Harness; Shifter	22	1	V-13B	Mounting Subplate; V-411 Pilot Valve
9	5	F-206	Fitting; 1/4 90 Degree Elbow MF	23	1	V-411E	Pilot Valve; 12V Hydraulic Shifter
10	2	F-211	Fitting; 1/4 to #4 JIC	24	1	RKIT-016	Linkage Kit
11	1	P-220	Fitting 1/8 to #4 JIC to Transmission	25	1	21525	Antivibration Kit
12	2	H-164	Nut; 5/8-11				
13	4	H-292	Cap Screw; #10-24 x 2.000 Skt Hd				
14	2	H-163	Cap Screw; 5/8-11 x 1.750 Hex Hd				

**NOTE**

\* Unit With Antivibration

**S-HS750-01 / S-HS750-01R\***

Transmission Station: Side Mount, Hydraulic, Electric Solenoids, 7-Range, RND4321  
GM Allison HT-750

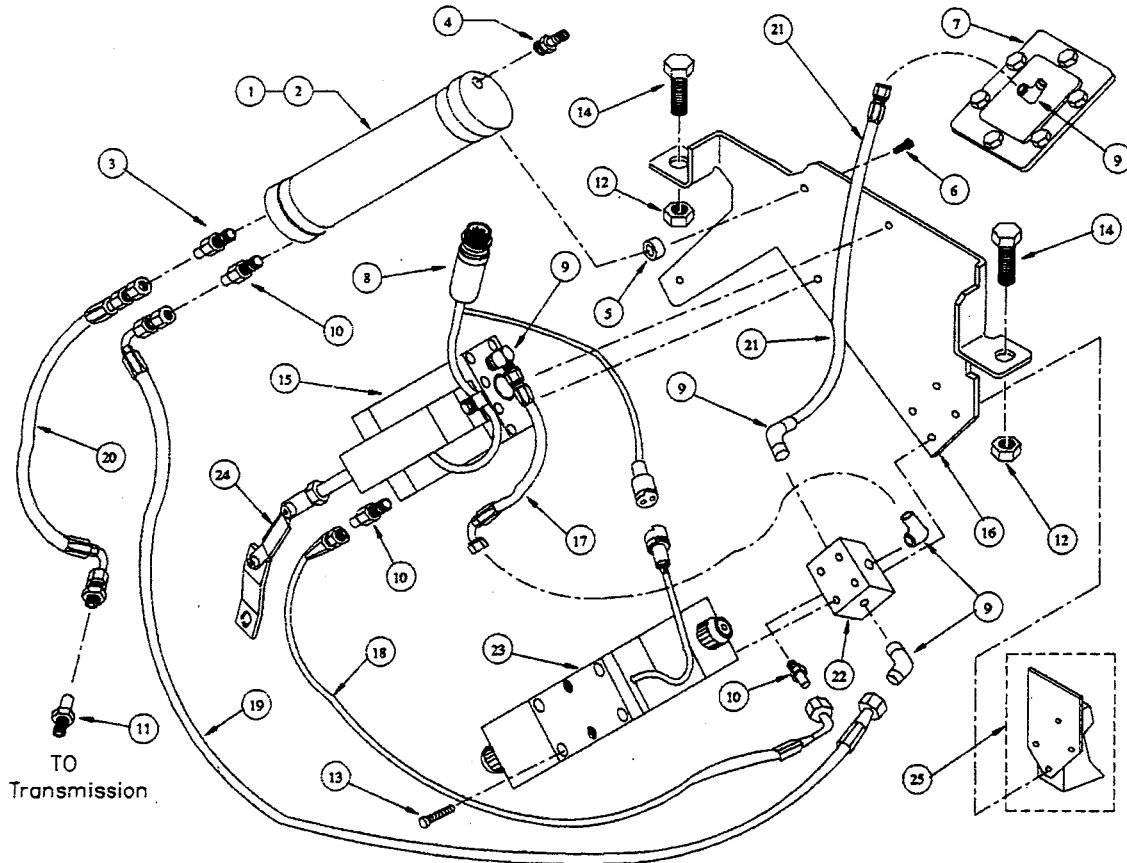

ITEM	QTY	PART #	DESCRIPTION	ITEM	QTY	PART #	DESCRIPTION
1	1	X30296-AV	Accumulator Assembly; Oil/Air 500 PSI, with All Fittings and Mounting Hardware (Items 2-6)	15	1	S-SB7-78A	Shifter Assembly; Side Mount Hydraulic HT-750
2	1	30296	Accumulator; Oil/Air 500 PSI	16	1	21 256	Mounting Bracket; Side Mount Hydraulic HT-750
3	1	21231	Check Valve; Hydraulic Accumulator	17	1	T-125.03	Hose Hydraulic; Top End Plate to Valve Subplate
4	1	30646	Filler; Air/Nitrogen Accumulator	18	1	T-127.10	Hose Hydraulic; Lower End Plate to Valve Subplate
5	2	C-27	Spacer; Accumulator Mounting	19	1	T-125.05	Hose Hydraulic; Accumulator to Valve Subplate
6	2	H-174	Cap Screw; 5/16-18 x 1.000 Whizlock	20	1	T-125.06	Hose Hydraulic; Accumulator to Transmission Pressure
7	1	21053	Cover Assembly; PTO Hydraulic Pump Return	21	1	T-127.03	Hose Hydraulic; Valve Subplate to PTO Cover
8	1	74044.01	Harness; Shifter	22	1	V-13B	Mounting Subplate; V-411 Pilot Valve
9	5	F-206	Fitting; 1/4 90 Degree Elbow MF	23	1	V-411E	Pilot Valve; 12V Hydraulic Shifter
10	2	F-211	Fitting; 1/4 to #4 JIC	24	1	RKIT-016	Linkage Kit
11	1	F-220	Fitting 1/8 to #4 JIC to Transmission	25	1	21525	Antivibration Kit
12	2	H-164	Nut; 5/8-11				
13	4	H-292	Cap Screw; #10-24 x 2.000 Skt Hd				
14	2	H-163	Cap Screw; 5/8-11 x 1.750 Hex Hd				

**NOTE**

- \* Unit With Antivibration

# S-HS540-01 / S-HS540-01R\*

Transmission Station: Side Mount, Hydraulic, 6-Range, RND321

GM Allison AT-540

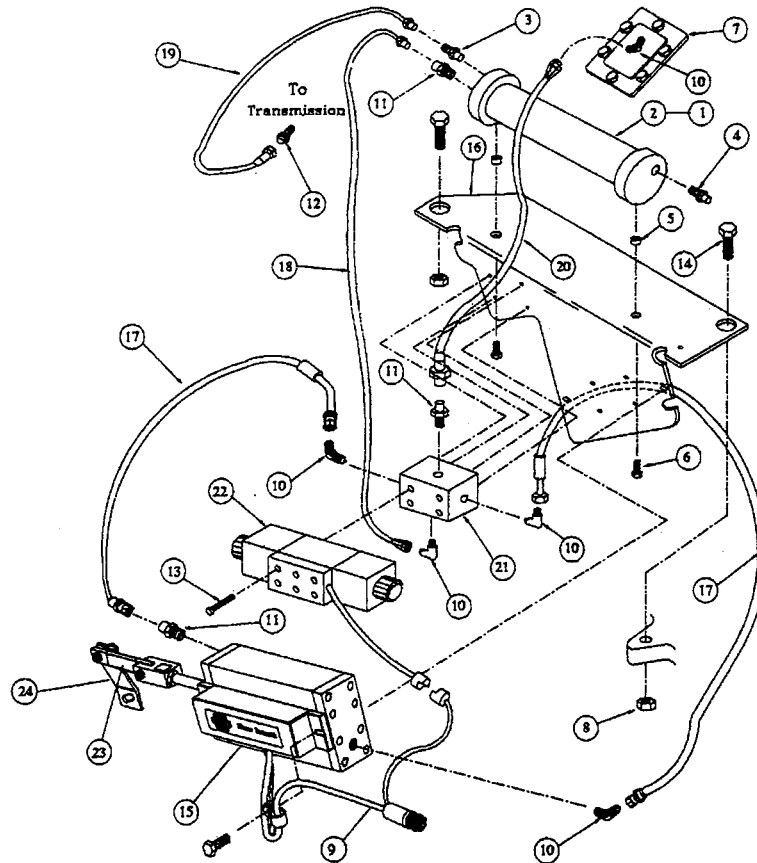

ITEM	QTY	PART #	DESCRIPTION	ITEM	QTY	PART #	DESCRIPTION
1	1	X30296-AV	Accumulator Assembly; Oil/Air 500 PSI, with all Fittings and Mounting Hardware (Items 2-6)	15	1	S-SB6-73A	Shifter Assembly; Side Mount Hydraulic AT-540
2	1	30296	Accumulator; Oil/Air 500 PSI	16	1	SB-6-26Z	Mounting Bracket; Side Mount Hydraulic AT-540
3	1	21231	Check Valve; Hydraulic Accumulator	17	1	T-125.02	Hose Hydraulic; End Plates to Valve Subplate
4	1	30646	Filler; Air/Nitrogen Accumulator	18	2	T-125.04	Hose Hydraulic; Accumulator to Valve Subplate
5	2	C-27	Spacer; Accumulator Mounting	19	1	T-125.06	Hose Hydraulic; Accumulator to Transmission Pressure
6	2	H-174	Cap Screw; 5/16-18 x 1.000 Whizlock	20	1	T-127.01	Hose Hydraulic; Valve Subplate to PTO Couvet
7	1	21053	Cover Assembly; PTO Hydraulic Pump Return	21	1	V-13B	Mounting Subplate; V-411 Pilot Valve
8	2	H-164	Nut; 5/8-11 15/16 Hex	22	1	V-411E	Pilot Valve; 12V Hydraulic Shifter
9	1	74044.01	Harness; Shifter	23	1	RKIT-016	Linkage Kit
10	5	F-206	Fitting; 1/4 90 Degree Elbow MF	24	1	SB-6-22G	Clamp Lever
11	2	F-211	Fitting; 1/4 to #4 JIC				
12	1	F-220	Fitting; 1/8 to #4 JIC to Transmission				
13	4	H-292	Cap Screw; #10-24 x 2.000 Skt Hd				
14	2	H-163	Cap Screw; 5/8-11 x 1.750 15/16 Hex				

**NOTE**

\* Unit With Antivibration

# S-AS654-01

Transmission Station: Side Mount, Air-Powered, Electric Solenoids, 7-Range, RND4321

GM Allison MT-654

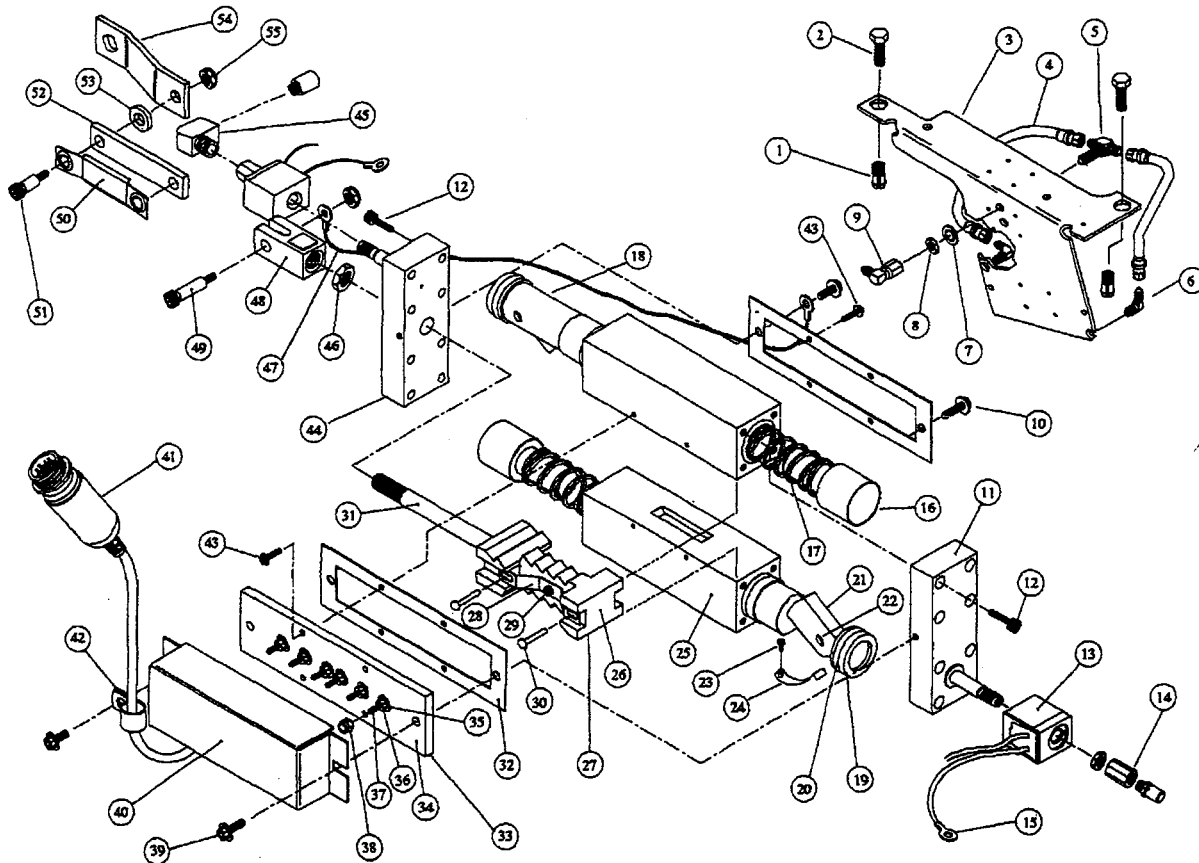

ITEM	QTY	PART #	DESCRIPTION	ITEM	QTY	PART #	DESCRIPTION
1	2	21261	Insert-Threaded; MT 600	29	1	H-281	Screw-Cap; 10-32 X 3/8, SK. HD.
2	2	H-386	Bolt; 1/2-13 X 1.125	30	2	C-38	Pin-Contact; All
3	1	SB-7-26L	Bracket-Mounting; MT600	31	1	SB-G-4E	Shaft-Shifter; 7 Range
4	2	T-121.09	Hose-Air; F/F 1/4" JIC #4	32	2	SB-7-14A	Gasket-Shifter; 7 Range
5	1	F-223	Fitting-Tee; Bulkhead	33	1	XSB-7-13M	Plate-Cover; Assembly (Items 34-38)
6	2	F-124	Elbow; 1/8 NPT-#4 JIC	34	1	SB-7-13M	Plate-Cover; Without Contacts
7	1	H-416	Washer-Flat; 7/16 ID	35	14	H-107	Washer; SS
8	1	F-224	Fitting-Nut; Bulkhead	36	7	H-106	Nut; SS
9	1	F-155	Elbow-Swivel; #4 JIC-#4 JIC	37	7	H-256	Screw; Oval Head, SS
10	2	H-270	Capscrew; 1/4-20 X 1/2 HEX HD.	38	7	H-149	Nut-Lock
11	1	21300A	End Plate with Valve & Valveseat (Items 13-15)	39	2	H-222	Screw; 1/4-20 X 5/8
12	16	H-126	Capscrew; 1/4-20 X 3/4, SK. HD.	40	1	SB-7-35B	Cover-Terminal; 7 Range
13	2	30428	Coil; Valve Operator, 12 Volts	41	1	75044.02	Harness-Shifter; with Amp 16 Pin, Connector
14	2	V-11	Valve-Exhaust; One Way Check	42	1	30226	Clamp-Harness; All
15	2	30719	Ring-Terminal; 18 AWG	43	8	H-226	Screw; 8-32 X 1/2
16	2	SB-7-10	Plug-Stop; 7 Range	44	1	21299	Plate-End; Assy. w/Shaft Seal & Valve (Items 13-15)
17	2	C-11	Spring-Return; Piston, Air	45	1	F-227	Elbow
18	2	XSB-5-2	Piston-Assembly; Air (Items 19, 21-24)	46	1	H-227	Nut-Jam; 1/2 X 14
19	2	C-2D	Piston-Air	47	1	SB-7-25A	Strap-Ground; All
20	2	30513	O'Ring; O'Ring Air, Piston (sold sep.)	48	1	SB-6-21D	Clevis
21	2	SB-5-7	Pawl-Piston; Air	49	1	H-316	Bolt-Shoulder; 1/4-20 X 1.25, SK. HD.
22	2	H-214	Pin-Dowel; 1/4 X 1	50	1	21600	Spring-Antivibration; Linkage
23	2	H-104	Screw; 6-32 X 1/4, Plated	51	1	H-260	Bolt-Shoulder; 1/4-20 X .825, SK. HD.
24	2	C-9	Spring-Pawl; Air	52	1	SB-6-23D	Link; Lever-Clevis
25	2	SB-7-1A	Cylinder; 7 Range	53	1	21606	Spacer; .50 OD X .312 ID, SS
26	1	XSB-7-3M	Ratchet-Assembly; (Items 27-29)	54	1	SB-7-22G	Lever; Selector Shaft
27	1	SB-7-3E1	Ratchet; 5/6/7 Range, Air	55	2	H-257	Nut-Lock; 1/4-20
28	1	SB-7-15A	Spring-Contact; Electric Indication				



**S-AS653-01**

Transmission Station: Side Mount, Air-Powered, Electric Solenoids, 6-Range, RND321  
GM Allison MT-643/44/47/53

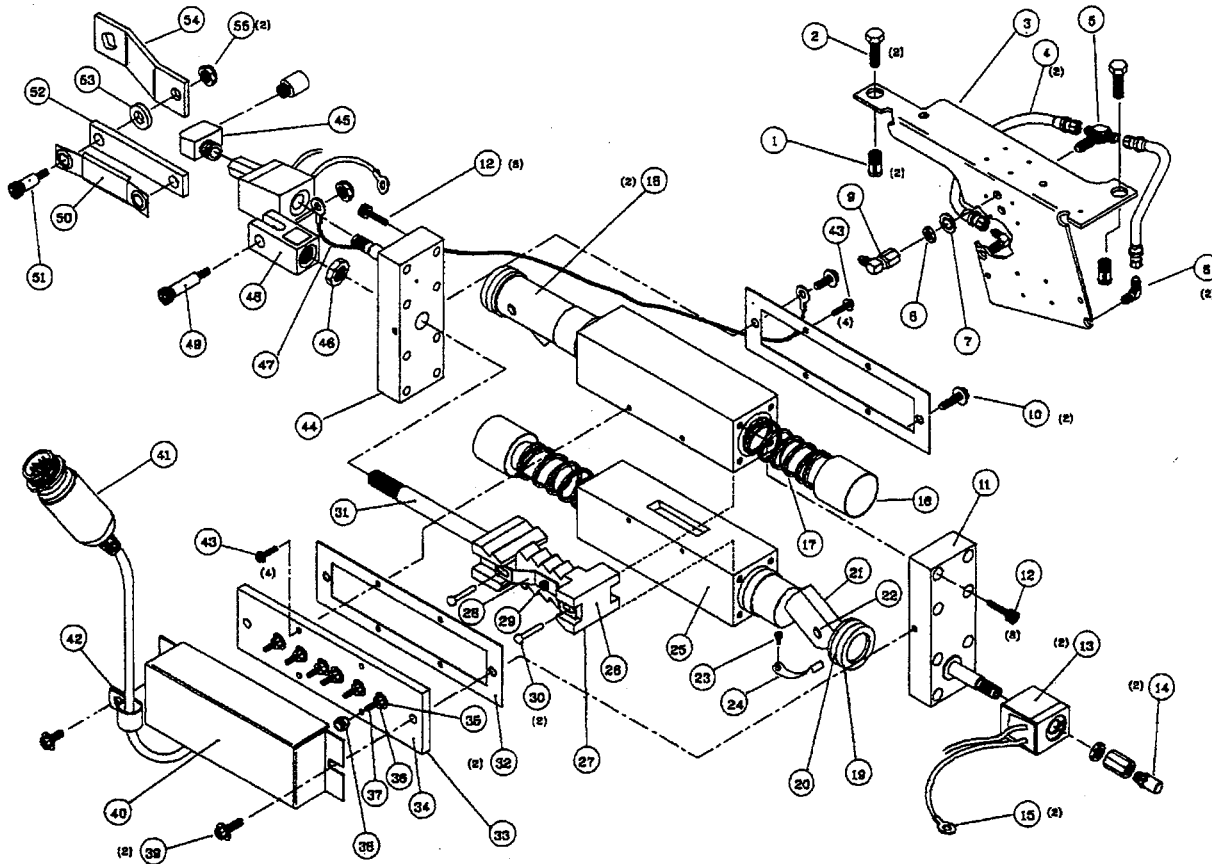

ITEM	QTY	PART #	DESCRIPTION	ITEM	QTY	PART #	DESCRIPTION
1	2	21261	Insert-Threaded; MT 600	29	1	H-281	Screw-Cap; 10-32 X 3/8, SK. HD.
2	2	H-386	Bolt; 1/2-13 X 1.125	30	2	C-38	Pin-Contact; All
3	1	SB-6-26Y	Bracket-Mounting; MT600	31	1	SB-G-4D	Shaft-Shifter; 6 Range
4	2	T-121.09	Hose-Air; F/F 1/4" JIC #4	32	2	SB-6-14A	Gasket-Shifter; 6 Range
5	1	F-223	Fitting-Tee; Bulkhead	33	1	XSB-6-13P	Plate-Cover; Assembly (Items 34-38)
6	2	F-124	Elbow; 1/8 NPT-#4 JIC	34	1	SB-6-13P	Plate-Cover; Without Contacts
7	1	H-416	Washer-Flat; 7/16 ID	35	12	H-107	Washer; SS
8	1	F-224	Fitting-Nut; Bulkhead	36	6	H-106	Nut; SS
9	1	H-155	Elbow-Swivel; #4 JIC-#4 JIC	37	6	H-256	Screw; Oval Head, SS
10	2	H-270	Capscrew; 1/4-20 X 1/2 HEX HD.	38	6	H-149	Nut-Lock
11	1	21300A	End Plate with Valve & Valveseat	39	2	H-222	Screw; 1/4-20 X 5/8
12	16	H-126	Capscrew; 1/4-20 X 3/4, SK. HD.	40	1	SB-6-35B	Cover-Terminal; 6 Range
13	2	30428	Coil; Valve Operator, 12 Volts	41	1	75044.02	Harness-Shifter; with Amp 16 Pin, Connector
14	2	V-11	Valve-Exhaust; One Way Check	42	1	30226	Clamp-Harness; All
15	2	30719	Ring-Terminal; 18 AWG	43	8	H-226	Screw; 8-32 X 1/2
16	2	SB-6-10	Plug-Stop; 6 Range	44	1	21299	Plate-End; Assy. w/Shaft Seal & Valve
17	2	C-11	Spring-Return; Piston, Air	45	1	F-227	Elbow
18	2	XSB-5-2	Piston-Assembly; Air (Items 19, 21-24)	46	1	H-227	Nut-Jam; 1/2 X 14
19	2	C-2D	Piston-Air	47	1	SB-7-25A	Strap-Ground; All
20	2	30513	O'Ring; O'Ring Air, Piston (sold sep.)	48	1	SB-6-21D	Clevis; 1/2-14
21	2	SB-5-7	Pawl-Piston; Air	49	1	H-316	Bolt-Shoulder; 1/4-20 X 1.25, SK. HD.
22	2	H-214	Pin-Dowel; 1/4 X 1	50	1	21600	Spring-Antivibration; Linkage
23	2	H-104	Screw; 6-32 X 1/4, Plated	51	1	H-260	Bolt-Shoulder; 1/4-20 X .825, SK. HD.
24	2	C-9	Spring-Pawl; Air	52	1	SB-6-23D	Link; Lever-Clevis
25	2	SB-6-1A	Cylinder; 6 Range	53	1	21606	Spacer; .50 OD X .312 ID, SS
26	1	XSB-7-3H	Ratchet-Assembly; (Items 27-29)	54	1	SB-6-22F	Lever; Selector Shaft
27	1	SB-7-3E1	Ratchet; 5/6/7 Range, Air	55	2	H-257	Nut-Lock; 1/4-20
28	1	SB-5-15	Spring-Contact; Electric Indication				

# S-AS750-01

Transmission Station: Side Mount, Air-Powered, Electric Solenoids, 7-Range, RND4321

GM Allison HT-750/754

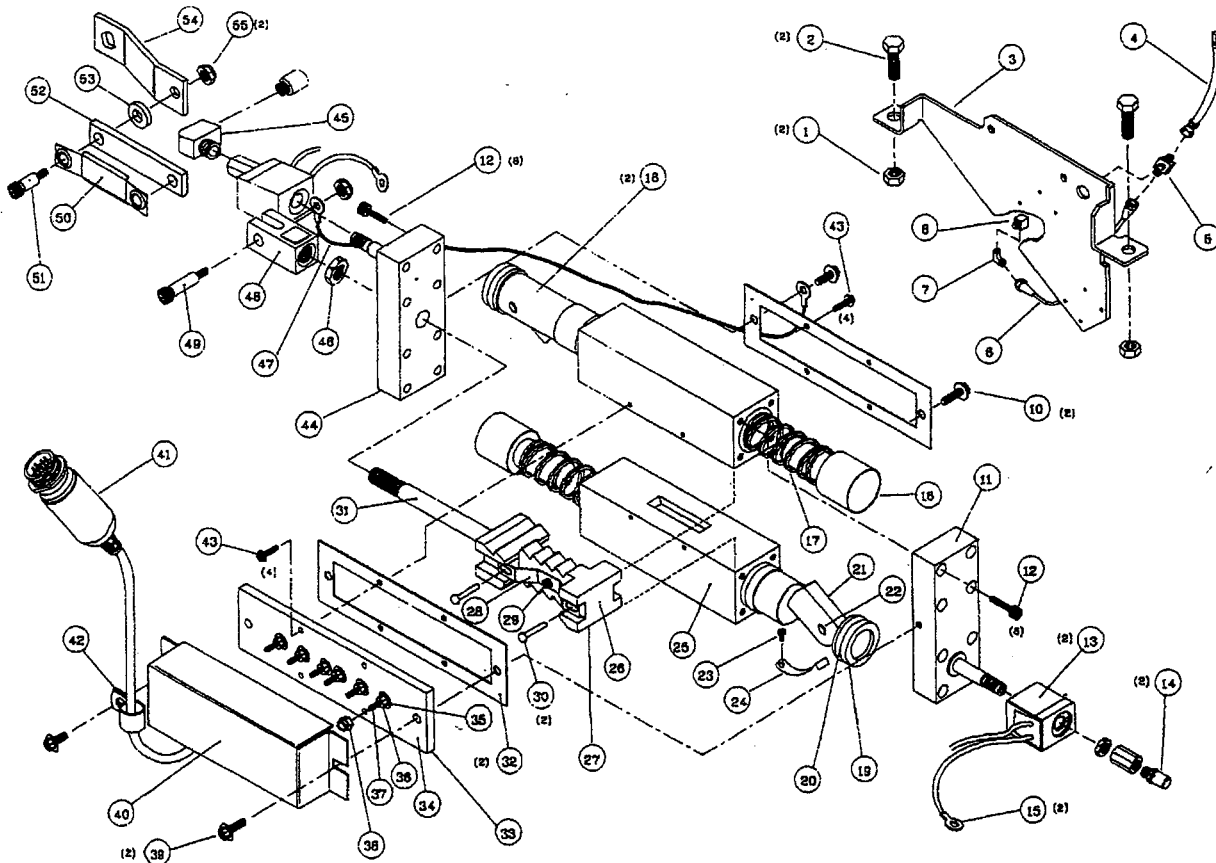

ITEM	QTY	PART #	DESCRIPTION	ITEM	QTY	PART #	DESCRIPTION
1	2	H-163	Nut, Nylon Insert	29	1	H-281	Screw-Cap: 10-32 X 3/8, SK. HD.
2	2	H-164	Capscrew	30	2	C-38	Pin-Contact; All
3	1	21256A	Bracket-Mounting; HT-700	31	1	SB-G-4E	Shaft-Shifter; 7 Range
4	1	T-129.01	Hose-Air: F/F 1/4" JIC #4	32	2	SB-7-14A	Gasket-Shifter; 7 Range
5	1	F-226	Fitting-Tee; Bulkhead	33	1	XSB-7-13M	Plate-Cover; Assembly (Items 34-38)
6	1	21526	Elbow; 1/8 NPT-#4 JIC	34	1	SB-7-13M	Plate-Cover; Without Contacts
7	1	F-124	Washer-Flat; 7/16 ID	35	14	H-107	Washer; SS
8	1	F-227	Fitting-Nut; Bulkhead	36	7	H-106	Nut; SS
9				37	7	H-256	Screw: Oval Head, SS
10	2	H-270	Capscrew: 1/4-20 X 1/2 HEX HD.	38	7	H-149	Nut-Lock
11	1	21300A	End Plate with Valve & Valveseat	39	2	H-222	Screw: 1/4-20 X 5/8
12	16	H-126	Capscrew: 1/4-20 X 3/4, SK. HD.	40	1	SB-7-35B	Cover-Terminal; 7 Range
13	2	30428	Coil; Valve Operator, 12 Volts	41	1	75044.02	Harness-Shifter; with Amp 16 Pin, Connector
14	2	V-11	Valve-Exhaust; One Way Check	42	1	30226	Clamp-Harness; All
15	2	30719	Ring-Terminal; 18 AWG	43	8	H-226	Screw: 8-32 X 1/2
16	2	SB-7-10	Plug-Stop; 7 Range	44	1	21299	Plate-End; Assy. w/Shaft Seal & Valve
17	2	C-11	Spring-Return; Piston, Air	45	1	F-227	Elbow
18	2	XSB-5-2	Piston-Assembly; Air (Items 19, 21-24)	46	1	H-227	Nut-Jam; 1/2 X 14
19	2	C-2D	Piston-Air	47	1	SB-7-25A	Strap-Ground; All
20	2	30513	O'Ring; O'Ring Air, Piston (sold sep.)	48	1	SB-6-21D	Clevis; 1/2-14
21	2	SB-5-7	Pawl-Piston; Air	49	1	H-316	Bolt-Shoulder; 1/4-20 X 1.25, SK. HD.
22	2	H-214	Pin-Dowel: 1/4 X 1	50	1	21600	Spring-Antivibration; Linkage
23	2	H-104	Screw: 6-32 X 1/4, Plated	51	1	H-260	Bolt-Shoulder; 1/4-20 X .825, SK. HD.
24	2	C-9	Spring-Pawl; Air	52	1	SB-6-23D	Link; Lever-Clevis
25	2	SB-7-1A	Cylinder; 7 Range	53	1	21606	Spacer; .50 OD X .312 ID, SS
26	1	XSB-7-3M	Ratchet-Assembly; (Items 27-29)	54	1	SB-7-22H	Lever; Selector Shaft
27	1	SB-7-3E1	Ratchet; 5/6/7 Range, Air	55	2	H-257	Nut-Lock; 1/4-20
28	1	SB-7-15A	Spring-Contact; Electric Indication				

**S-AS740-01**

Transmission Station: Side Mount, Air-Powered, Electric Solenoids, 6-Range, RND321

GM Allison HT-740/747

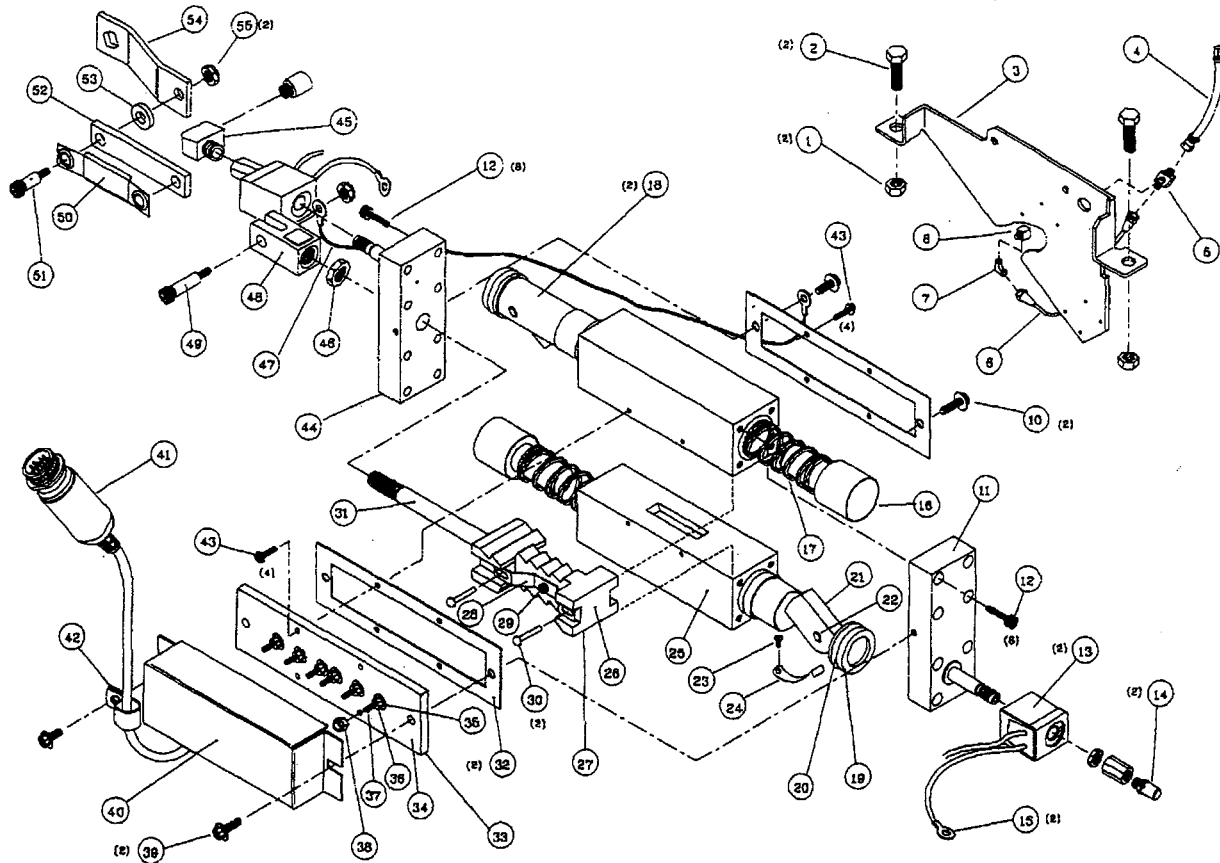

ITEM	QTY	PART #	DESCRIPTION	ITEM	QTY	PART #	DESCRIPTION
1	2	H-163	Nut, Nylon Insert	29	1	H-281	Screw-Cap; 10-32 X 3/8, SK. HD.
2	2	H-164	Capscrew	30	2	C-38	Pin-Contact; All
3	1	21256A	Bracket-Mounting; HT-700	31	1	SB-G-4E	Shaft-Shifter; 6 Range
4	1	T-129.01	Hose-Air; F/F 1/4" JIC #4	32	2	SB-7-14A	Gasket-Shifter; 6 Range
5	1	F-226	Fitting-Tee; Bulkhead	33	1	XSB-7-13M	Plats-Cover; Assembly (Items 34-38)
6	1	21526	Elbow; 1/8 NPT-#4 JIC	34	1	SB-7-13M	Plate-Cover; Without Contacts
7	1	F-124	Washer-Flat; 7/16 ID	35	12	H-107	Washer; SS
8	1	F-227	Fitting-Nut; Bulkhead	36	6	H-106	Nut; SS
9				37	6	H-256	Screw; Oval Head, SS
10	2	H-270	Capscrew; 1/4-20 X 1/2 HEX HD.	38	6	H-149	Nut-Lock
11	1	21300A	End Plate with Valve & Valveseat	39	2	H-222	Screw; 1/4-20 X 5/8
12	16	H-126	Capscrew; 1/4-20 X 3/4, SK. HD.	40	1	SB-7-35B	Cover-Terminal; 6 Range
13	2	30428	Coil; Valve Operator, 12 Volts	41	1	75044.02	Harness-Shifter; with Amp 16 Pin, Connector
14	2	V-11	Valve-Exhaust; One Way Check	42	1	30226	Clamp-Harness; All
15	2	30719	Ring-Terminal; 18 AWG	43	8	H-226	Screw; 8-32 X 1/2
16	2	SB-7-10	Plug-Stop; 6 Range	44	1	21299	Plate-End; Assy. w/Shaft Seal & Valve
17	2	C-11	Spring-Return; Piston, Air	45	1	F-227	Elbow
18	2	XSB-5-2	Piston-Assembly; Air (Items 19, 21-24)	46	1	H-227	Nut-Jam; 1/2 X 14
19	2	C-2D	Piston-Air	47	1	SB-7-25A	Strap-Ground; All
20	2	30513	O'Ring; O'Ring Air, Piston (sold sep.)	48	1	SB-6-21D	Clevis; 1/2-14
21	2	SB-5-7	Pawl-Piston; Air	49	1	H-316	Bolt-Shoulder; 1/4-20 X 1.25, SK. HD.
22	2	H-214	Pin-Dowel; 1/4 X 1	50	1	21600	Spring-Antivibration; Linkage
23	2	H-104	Screw; 6-32 X 1/4, Plated	51	1	H-260	Bolt-Shoulder; 1/4-20 X .825, SK. HD.
24	2	C-9	Spring-Pawl; Air	52	1	SB-6-23D	Link; Lever-Clevis
25	2	SB-7-1A	Cylinder; 6 Range	53	1	21606	Spacer; .50 OD X .312 ID, SS
26	1	XSB-7-3M	Ratchet-Assembly; (Items 27-29)	54	1	SB-7-22H	Lever; Selector Shaft
27	1	SB-7-3E1	Ratchet; 5/6/7 Range, Air	55	2	H-257	Nut-Lock; 1/4-20
28	1	SB-7-15A	Spring-Contact; Electric Indication				

# S-AS540-01

Transmission Station: Side Mount, Air-Powered, Electric Solenoids, 6-Range, RND321

GM Allison AT-540/545

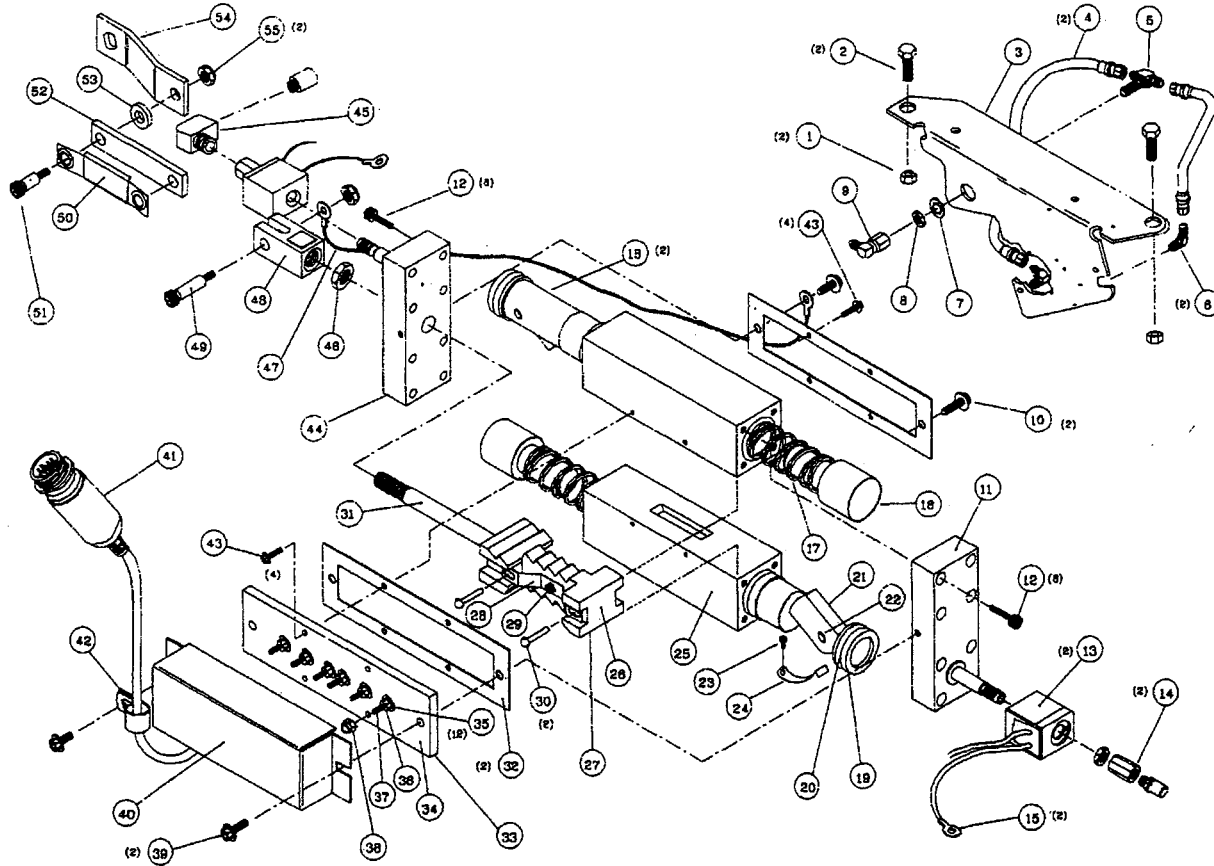

ITEM	QTY	PART #	DESCRIPTION	ITEM	QTY	PART #	DESCRIPTION
1	2	H-164	Nut: 5/8-11 X 15/16 with Insert	29	1	H-281	Screw-Cap: 10-32 X 3/8, SK. HD.
2	2	H-163	Bolt: 5/8-11 X 1.75	30	2	C-38	Pin-Contact: All
3	1	SB-6-26Z	Bracket-Mounting: MT600	31	1	SB-G-4D	Shaft-Shifter: 6 Range
4	2	T-121.09	Hose-Air: F/F 1/4" JIC #4	32	2	SB-6-14A	Gasket-Shifter: 6 Range
5	1	F-223	Fitting-Tee: Bulkhead	33	1	XSB-6-13P	Plate-Cover: Assembly (Items 34-38)
6	2	F-124	Elbow: 1/8 NPT-#4 JIC	34	1	SB-6-13P	Plate-Cover: Without Contacts
7	1	H-416	Washer-Flat: 7/16 ID	35	12	H-107	Washer: SS
8	1	F-224	Fitting-Nut: Bulkhead	36	6	H-106	Nut: SS
9	1	H-155	Elbow-Swivel: #4 JIC-#4 JIC	37	6	H-256	Screw: Oval Head, SS
10	2	H-270	Capscrew: 1/4-20 X 1/2 HEX HD.	38	6	H-149	Nut-Lock
11	1	21300A	End Plate with Valve & Valveseat	39	2	H-222	Screw: 1/4-20 X 5/8
12	16	H-126	Capscrew: 1/4-20 X 3/4, SK. HD.	40	1	SB-6-35B	Cover-Terminal: 6 Range
13	2	30428	Coil: Valve Operator, 12 Volts	41	1	75044.02	Harness-Shifter: with Amp 16 Pin, Connector
14	2	V-11	Valve-Exhaust; One Way Check	42	1	30226	Clamp-Harness: All
15	2	30719	Ring-Terminal: 18 AWG	43	8	H-226	Screw: 8-32 X 1/2
16	2	SB-6-10	Plug-Stop: 6 Range	44	1	21299	Plate-End: Assy. w/Shaft Seal & Valve
17	2	C-11	Spring-Return; Piston, Air	45	1	F-227	Elbow
18	2	XSB-5-2	Piston-Assembly; Air (Items 19, 21-24)	46	1	H-227	Nut-Jam: 1/2 X 14
19	2	C-2D	Piston-Air	47	1	SB-7-25A	Strap-Ground: All
20	2	30513	O'Ring; O'Ring Air, Piston (sold sep.)	48	1	SB-6-21D	Clevis: 1/2-14
21	2	SB-5-7	Pawl-Piston: Air	49	1	H-316	Bolt-Shoulder: 1/4-20 X 1.25, SK. HD.
22	2	H-214	Pin-Dowel: 1/4 X 1	50	1	21600	Spring-Antivibration: Linkage
23	2	H-104	Screw: 6-32 X 1/4, Plated	51	1	H-260	Bolt-Shoulder: 1/4-20 X .825, SK. HD.
24	2	C-9	Spring-Pawl: Air	52	1	SB-6-23D	Link: Lever-Clevis
25	2	SB-6-1A	Cylinder: 6 Range	53	1	21606	Spacer: .50 OD X .312 ID, SS
26	1	XSB-7-3H	Ratchet-Assembly; (Items 27-29)	54	1	SB-6-22G	Lever: Selector Shaft
27	1	SB-7-3E1	Ratchet; 5/67 Range, Air	55	2	H-257	Nut-Lock: 1/4-20
28	1	SB-5-15	Spring-Contact: Electric Indication				

# S-SB6-61A

Shifter Assembly: Hydraulic, Side Mount, 6-Range, RND321

GM Allison MT-643/644/653

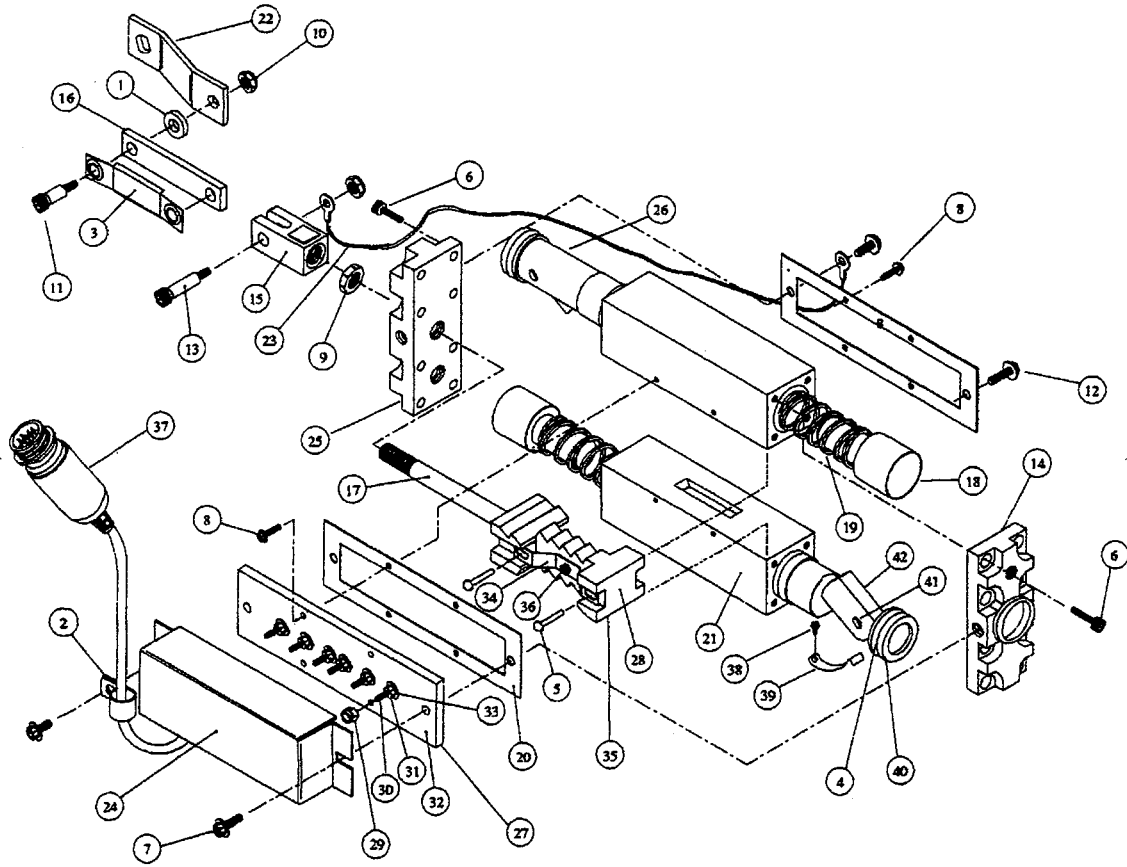

ITEM	QTY	PART #	DESCRIPTION	ITEM	QTY	PART #	DESCRIPTION
1	1	21606	Spacer; Linkage	23	1	SB-7-25A	Cable; Ground Strap
2	1	30226	Clamp; Harness	24	1	SB-6-35B	Cover; Terminal
3	1	21600	Spring; Link	25	1	XSB-5-12NA	End Plate; Shaft End with Scraper Seal
4	2	C-16	O-Ring; Piston	26	2	XSB-5-2A	Piston Assembly; Hydraulic (Items 38-42)
5	2	C-38	Contact Pin; Shifter	27	1	XSB-6-13P	Contact Plate Assembly; 6 Range (Items 29-32)
6	16	H-126	Cap Screw; 1/4-20 X .750, SKT. HD.	28	1	XSB-7-3H	Ratchet Assembly; 6 Range
7	2	H-222	Cap Screw; 1/4-20 X .625, Whizlock	29	6	H-149	Locknut; Cover Plate
8	8	H-226	Cap Screw; 8-32 X .500, Whizlock	30	6	H-256	Screw; Oval HD., S.S.
9	1	H-227	Nut; 1/2-20	31	6	H-106	Nut; S.S.
10	1	H-257	Nut; 1/4-20, Lock with Nylon Insert	32	1	SB-6-13P	Contact Plate
11	1	H-260	Cap Screw; 1/4-20 X .825, S.H.	33	12	H-107	Washer; S.S.
12	2	H-270	1/4-20 X .500, Whizlock	34	1	SB-5-15	Spring; Contact, Electric Indication
13	1	H-316	Cap Screw; 1/4-20 X 1.200, S.H.	35	1	SB-7-3E1	Ratchet; Hydraulic
14	1	SB-5-12PA	End Plate; Shifter, Blank End	36	1	H-281	Cap Screw; 10-20 X 3/8, S.H.
15	1	SB-6-21D	Linkage Clevis; Shifter	37	1	74044.01	Hames; Shifter (Sold Separately)
16	1	SB-6-23D	Linkage Link; Shifter	38	2	H-104	Screw; 6-32 X 1/4, Plated
17	1	SB-G-4D	Shaft; Shifter	39	2	C-9	Spring; Pawl
18	2	SB-6-10	Stop Plug; 6 Range	40	2	C-2DA	Piston; Hydraulic
19	2	SB-7-11	Spring Return; Hydraulic	41	2	H-214	Pin; Pawl
20	2	SB-6-14A	Gasket; 6 Range	42	2	SB-5-7	Pawl; Piston
21	2	SB-6-1A	Cylinder; 6 Range				
22	1	SB-6-22F	Selector Shaft Lever; MT-643/644/653 Side Mount				

**S-SB7-67A**

Shifter Assembly: Hydraulic, Side Mount, 7-Range, RND4321

GM Allison MT-654

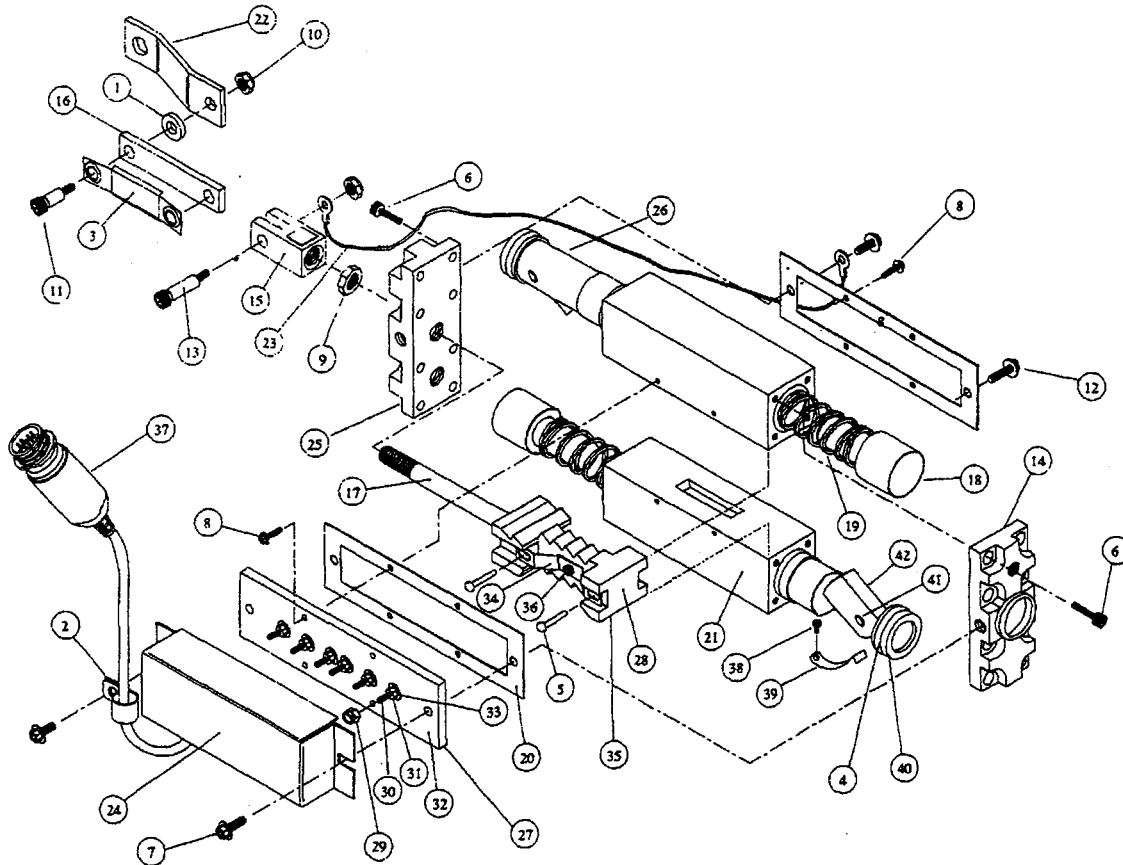

ITEM	QTY	PART #	DESCRIPTION	ITEM	QTY	PART #	DESCRIPTION
1	1	21606	Spacer; Linkage	23	1	SB-7-25A	Cable; Ground Strap
2	1	30226	Clamp; Harness	24	1	SB-7-35B	Cover; Terminal
3	1	21600	Spring; Link	25	1	XSB-5-12NA	End Plate; Shaft End with Scraper Seal
4	2	C-16	O-Ring; Piston	26	2	XSB-5-2A	Piston Assembly; Hydraulic (Items 38-42)
5	2	C-38	Contact Pin; Shifter	27	1	XSB-7-13M	Contact Plate Assembly; 7 Range (Items 29-32)
6	16	H-126	Cap Screw; 1/4-20 X .750, SKT. HD.	28	1	XSB-7-3M	Ratchet Assembly; 7 Range
7	2	H-222	Cap Screw; 1/4-20 X .625, Whizlock	29	7	H-149	Locknut; Cover Plate
8	8	H-226	Cap Screw; 8-32 X .500, Whizlock	30	7	H-256	Screw; Oval HD., S.S.
9	1	H-227	Nut; 1/2-20	31	7	H-106	Nut; S.S.
10	1	H-257	Nut; 1/4-20, Lock with Nylon Insert	32	1	SB-7-13M	Contact Plate
11	1	H-260	Cap Screw; 1/4-20 X .825, S.H.	33	14	H-107	Washer; S.S.
12	2	H-270	1/4-20 X .500, Whizlock	34	1	SB-7-15A	Spring; Contact, Electric Indication
13	1	H-316	Cap Screw; 1/4-20 X 1.200, S.H.	35	1	SB-7-3E1	Ratchet; Hydraulic
14	1	SB-5-12PA	End Plate; Shifter, Blank End	36	1	H-281	Cap Screw; 10-20 X 3/8, S.H.
15	1	SB-6-21D	Linkage Clevis; Shifter	37	1	74044.01	Harnes; Shifter (Sold Separately)
16	1	SB-6-23D	Linkage Link; Shifter	38	2	H-104	Screw; 6-32 X 1/4, Plated
17	1	SB-G-4E	Shaft; Shifter	39	2	C-9	Spring; Pawl
18	2	SB-7-10	Stop Plug; 7 Range	40	2	C-2DA	Piston; Hydraulic
19	2	SB-7-11	Spring Return; Hydraulic	41	2	H-214	Pin; Pawl
20	2	SB-7-14A	Gasket; 7 Range	42	2	SB-5-7	Pawl; Piston
21	2	SB-7-1A	Cylinder; 7 Range				
22	1	SB-7-22G	Selector Shaft Lever; MT-654 Side Mount				

# S-SB7-78A

Shifter Assembly: Hydraulic, Side Mount, 6 and 7 Range\*, RND321/RND4321

GM Allison HT-740/750 Series

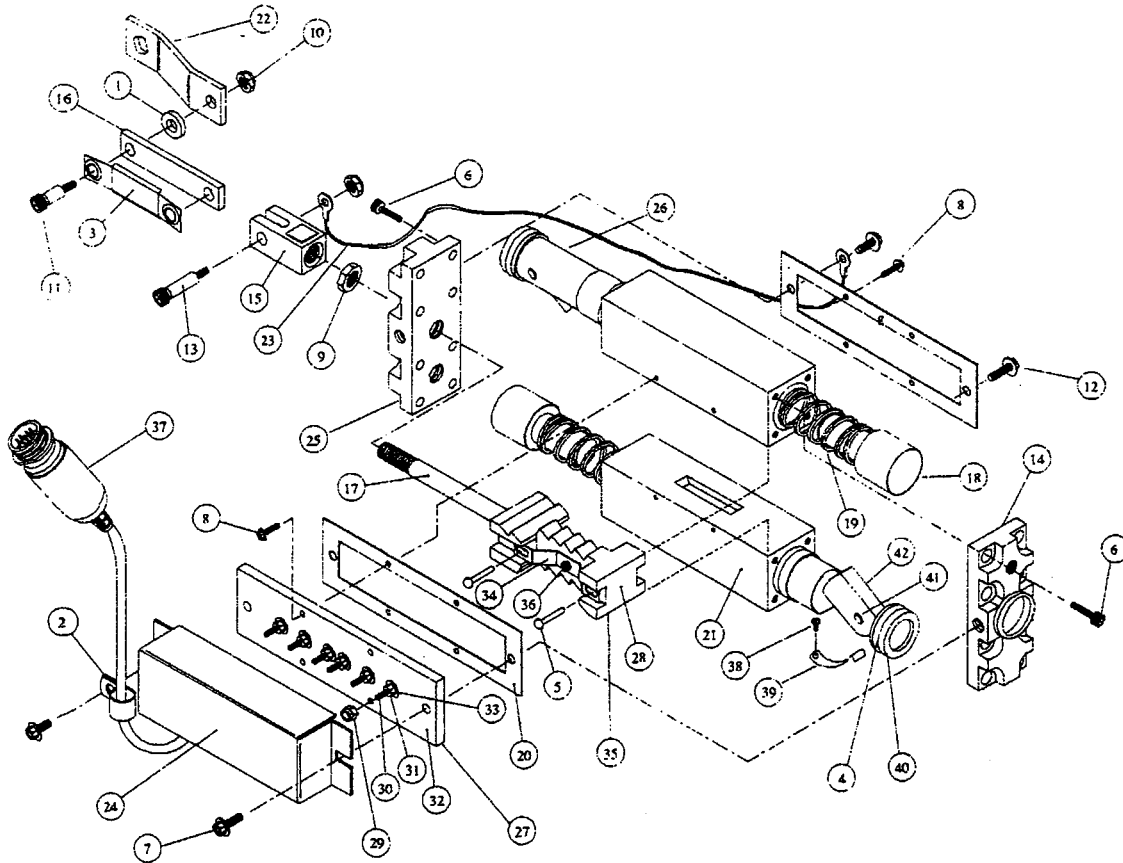

ITEM	QTY	PART #	DESCRIPTION	ITEM	QTY	PART #	DESCRIPTION
1	1	21606	Spacer: Linkage	23	1	SB-7-25A	Cable: Ground Strap
2	1	30226	Clamp: Harness	24	1	SB-7-35B	Cover: Terminal
3	1	21600	Spring: Link	25	1	XSB-5-12NA	End Plate: Shaft End with Scraper Seal
4	2	C-16	O-Ring: Piston	26	2	XSB-5-2A	Piston Assembly: Hydraulic (Items 38-42)
5	2	C-38	Contact Pin: Shifter	27	1	XSB-7-13M	Contact Plate Assembly: 7 Range (Items 29-32)
6	16	H-126	Cap Screw: 1/4-20 X .750, SKT. HD.	28	1	XSB-7-3L	Ratchet Assembly: 6/7 Range
7	2	H-222	Cap Screw: 1/4-20 X .625, Whizlock	29	7	H-149	Locknut: Cover Plate
8	8	H-226	Cap Screw: 8-32 X .500, Whizlock	30	7	H-256	Screw: Oval HD., S.S.
9	1	H-227	Nut: 1/2-20	31	7	H-106	Nut: S.S.
10	1	H-257	Nut: 1/4-20, Lock with Nylon Insert	32	1	SB-7-13M	Contact Plate
11	1	H-260	Cap Screw: 1/4-20 X .825, S.H.	33	14	H-107	Washer: S.S.
12	2	H-270	1/4-20 X .500, Whizlock	34	1	SB-7-15A	Spring: Contact, Electric Indication
13	1	H-316	Cap Screw: 1/4-20 X 1.200, S.H.	35	1	SB-7-3E	Ratchet: Hydraulic
14	1	SB-5-12PA	End Plate: Shifter, Blank End	36	1	H-281	Cap Screw: 10-20 X 3/8, S.H.
15	1	SB-6-21D	Linkage Clevis: Shifter	37	1	74044.01	Harness: Shifter (Sold Separately)
16	1	SB-6-23D	Linkage Link: Shifter	38	2	H-104	Screw: 6-32 X 1/4, Plated
17	1	SB-G-4E	Shaft: Shifter	39	2	C-9	Spring: Pawl
18	2	SB-7-10	Stop Plug: 7 Range	40	2	C-2DA	Piston: Hydraulic
19	2	SB-7-11	Spring Return: Hydraulic	41	2	H-214	Pin: Pawl
20	2	SB-7-14A	Gasket: 7 Range	42	2	SB-5-7	Pawl: Piston
21	2	SB-7-1A	Cylinder: 7 Range				
22	1	SB-7-22H	Selector Shaft Lever: HT-740/750 Side Mount				

**NOTE**

\* Refer to HT-740 Wiring Diagram

**S-SB6-73A**

Shifter Assembly: Hydraulic, Side Mount, 6-Range, RND321

GM Allison AT-540

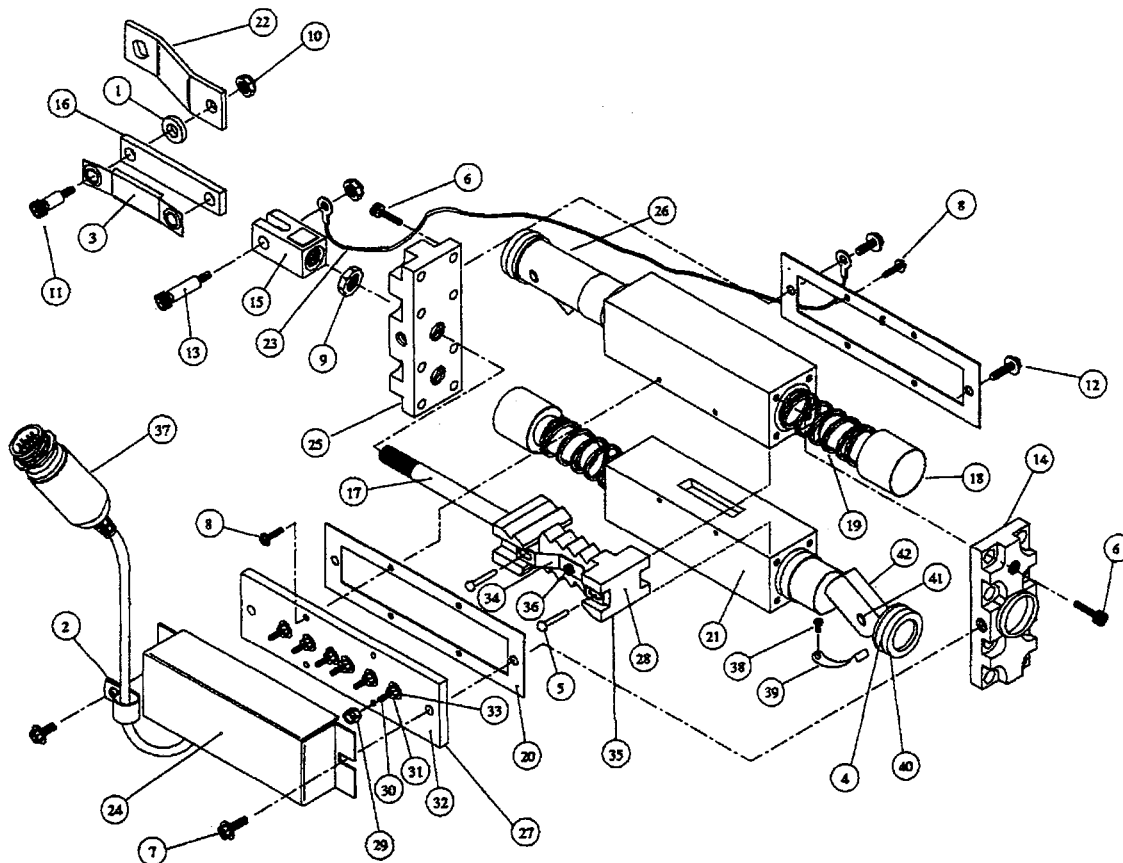

ITEM	QTY	PART #	DESCRIPTION	ITEM	QTY	PART #	DESCRIPTION
1	1	21606	Spacer; Linkage	23	1	SB-7-25A	Cable; Ground Strap
2	1	30226	Clamp; Harness	24	1	SB-6-35B	Cover; Terminal
3	1	21600	Spring; Link	25	1	XSB-5-12NA	End Plate; Shaft End with Scraper Seal
4	2	C-16	O-Ring; Piston	26	2	XSB-5-2A	Piston Assembly; Hydraulic (Items 38-42)
5	2	C-38	Contact Pin; Shifter	27	1	XSB-6-13P	Contact Plate Assembly; 6 Range (Items 29-32)
6	16	H-126	Cap Screw; 1/4-20 X .750, SKT. HD.	28	1	XSB-7-3H	Ratchet Assembly; 6 Range
7	2	H-222	Cap Screw; 1/4-20 X .625, Whizlock	29	6	H-149	Locknut; Cover Plate
8	8	H-226	Cap Screw; 8-32 X .500, Whizlock	30	6	H-256	Screw; Oval HD., S.S.
9	1	H-227	Nut; 1/2-20	31	6	H-106	Nut; S.S.
10	1	H-257	Nut; 1/4-20, Lock with Nylon Insert	32	1	SB-6-13P	Contact Plate
11	1	H-260	Cap Screw; 1/4-20 X .825, S.H.	33	12	H-107	Washer; S.S.
12	2	H-270	1/4-20 X .500, Whizlock	34	1	SB-5-15	Spring; Contact, Electric Indication
13	1	H-316	Cap Screw; 1/4-20 X 1.200, S.H.	35	1	SB-7-3E1	Ratchet; Hydraulic
14	1	SB-5-12PA	End Plate; Shifter, Blank End	36	1	H-281	Cap Screw; 10-20 X 3/8, S.H.
15	1	SB-6-21D	Linkage Clevis; Shifter	37	1	74044.01	Harness; Shifter (Sold Separately)
16	1	SB-6-23D	Linkage Link; Shifter	38	2	H-104	Screw; 6-32 X 1/4, Plated
17	1	SB-G-4D	Shaft; Shifter	39	2	C-9	Spring; Pawl
18	2	SB-6-10	Stop Plug; 6 Range	40	2	C-2DA	Piston; Hydraulic
19	2	SB-7-11	Spring Return; Hydraulic	41	2	H-214	Pin; Pawl
20	2	SB-6-14A	Gasket; 6 Range	42	2	SB-5-7	Pawl; Piston
21	2	SB-6-1A	Cylinder; 6 Range				
22	1	SB-6-22G	Selector Shaft Lever; MT-643/644/653 Side Mount				



# RKIT-016

## Linkage Kit, Side Mount Hydraulic Shifter All Transmissions

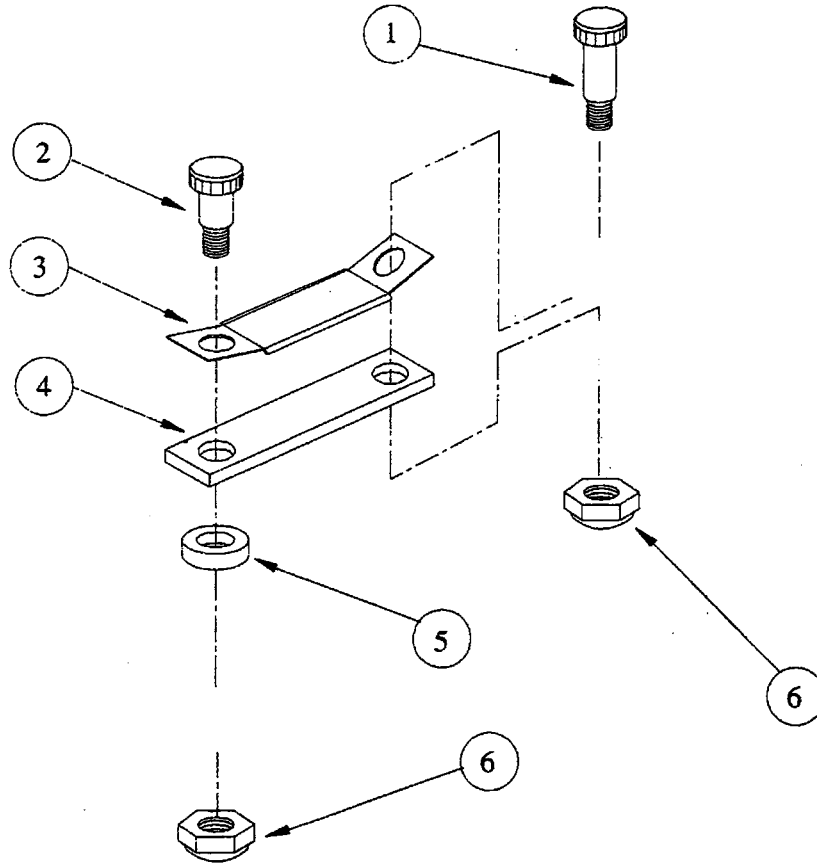

ITEM	QTY	PART #	DESCRIPTION	ITEM	QTY	PART #	DESCRIPTION
1	1	H-316	Shoulder Bolt: 1/4-20 X .750	4	1	SB-6-23D	Link: Side Mount
2	1	H-260	Shoulder Bolt: 1/4-20 X .370	5	1	21606	Spacer; Link
3	1	21600	Spring; Link	6	2	H-257	Nut; 1/4-20, Nylon Insert



 **Froude Hofmann Inc.**

45225 Polaris Court  
Plymouth, MI. 48170  
USA

Part of

 **Froude Hofmann**

Blackpole Road, Worcester WR3 8YB, England  
Tel:44 (0) 1905 85800 Fax: 44 (0) 1905 856811

PART OF THE  FKI GROUP OF COMPANIES